

**INSTALLATION INSTRUCTIONS FOR LP KIT (LB-107321G, H,; 53W69, 53W70)  
USED ON TG/KG/LGH 024-090 PACKAGED ROOFTOP UNITS**

**! WARNING**

This conversion kit shall be installed by a qualified service agency in accordance with the manufacturer's instructions and all applicable codes and requirements of the authority having jurisdiction. If the information in these instructions is not followed exactly, a fire, an explosion or production of carbon monoxide may result causing property damage, personal injury or loss of life. The qualified service agency is responsible for the proper installation of this kit. The installation is not proper and complete until the operation of the converted appliance is checked as specified in the manufacturer's instructions supplied with the kit.

**Requirements**

This conversion kit shall be installed by a qualified service agency. A qualified service agency is any individual, firm, corporation or company which either in person or through a representative is engaged in and is responsible for the connection, installation, repair or servicing of gas utilization equipment or accessories, who is experienced in such work, familiar with all precautions required, and has complied with all the requirements of the authority having jurisdiction.

*Canadian installations only - The conversion shall be carried out in accordance with the requirements of the Provincial authorities having jurisdiction and in accordance with the requirements of the CAN/CGA-B149.1 and .2 Installation Code.*

**Application**

The LP/propane gas changeover kit is required for gas conversion on TG/KG/LGH 024-090 units as follows:

Single stage gas valve - 53W69 (LB-107321G)

Two stage gas valve - 53W70 (LB-107321H)

See the unit nameplate to determine whether the unit has a single- or two-stage gas valve. An H or U in the 10th character of the model number indicates the unit is equipped with a two-stage gas valve. S, M, and T mean the unit contains a single-stage gas valve. For example, TGA060S2BH1G would contain a two-stage gas valve.

**Installation**

**! WARNING**

**Improper installation, adjustment, alteration, service or maintenance can cause property damage, personal injury or loss of life. Installation and service must be performed by a qualified installer, service agency or the gas supplier**

1- Open compressor and heat section access panels and close manual knob on gas valve.

506199-01

**Shipping and Packing List**

**53W69**

**Package 1 of 1 contains:**

- 7- Orifices
- 1- Spring kit
- 1- Bag assembly containing:
  - 1-Conversion plate
  - 1-Conversion sticker

**53W70**

**Package 1 of 1 contains:**

- 7- Orifices
- 1- Spring kit
- 1- Bag assembly containing:
  - 1-Conversion plate
  - 1-Conversion sticker
  - 1-Pressure switch
  - 1-Nipple
  - 2-Jumper plugs (only 1 used; discard other)
  - 1-Jumper wire

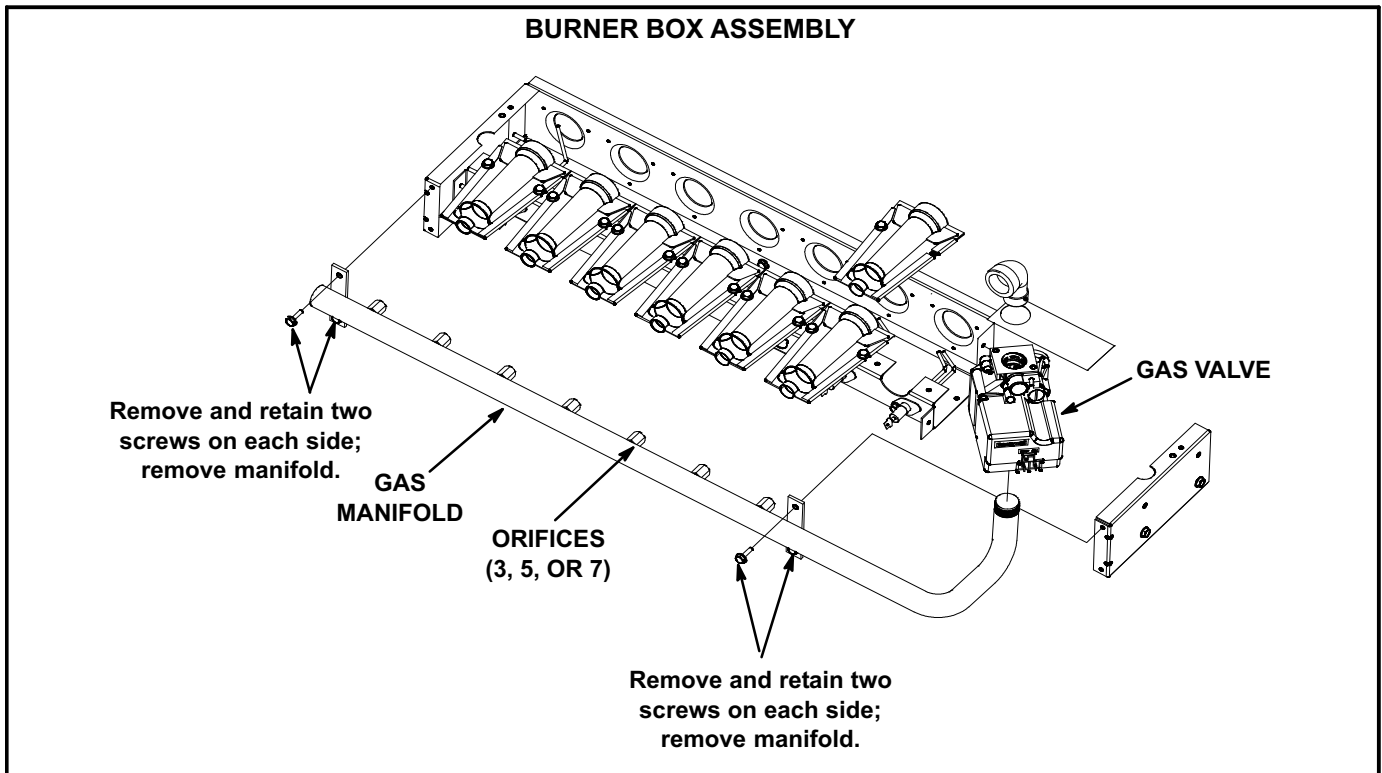

**FIGURE 1**

## **CAUTION**

**Danger of sharp metallic edges. Can cause injury. Take care when servicing unit to avoid accidental contact with sharp edges.**

*IMPORTANT-The gas supply shall be shut off prior to disconnecting the electrical power, before proceeding with this conversion.*

- 2- Remove the mullion between heat and compressor sections.
- 3- Turn main manual shut-off valve off and turn off electrical supply to unit. Set thermostat to "Off" position.
- 4- Remove and retain four screws securing manifold to burner box; remove manifold. See figure 1.
- 5- Remove orifices from manifold and install the orifices provided in kit. Unit will have 3, 5, or 7 burners. Replace only the orifices which have a burner installed.

**CAUTION - Tighten orifices with pipe threads to 6.25 ft.lbs. Do not overtighten.**

*IMPORTANT - Do not use thread compound on gas orifices.*

- 6- Replace the manifold and secure with retained screws.

- 7- Install spring kit as shown in figure 3 for single-stage gas valves and figure 2 for two-stage gas valves. Also refer to the manufacturer's instructions provided with spring kit.

### **CONVERTING TWO-STAGE GAS VALVE (Natural to LP/Propane)**

1. Turn off the gas supply to the unit.
2. Remove the pressure regulator cover assembly. See the gas valve illustration below.
3. Remove the existing stem/spring assembly.
4. Insert the replacement stem/spring assembly.
5. Replace the pressure regulator cover assembly and tighten the screws.
6. Apply the conversion label to the gas control.

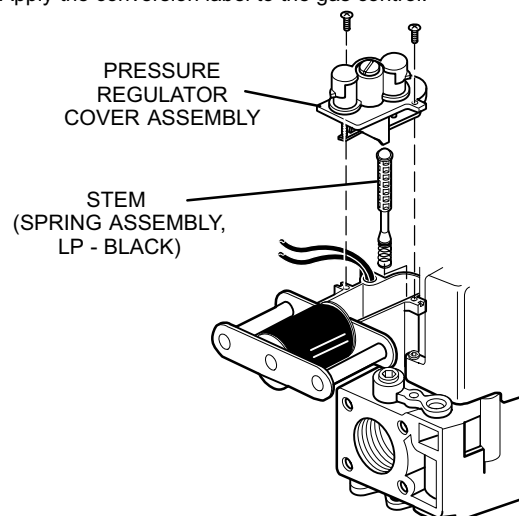

**FIGURE 2**

### CONVERTING SINGLE-STAGE GAS VALVE (Natural to LP)

1. Remove regulator cap screw and pressure regulator adjusting screw.
2. Remove existing spring.
3. Insert replacement spring.
4. Install the new plastic pressure regulator adjustment screw so that the top of the screw is flush (level) with the top of the regulator. Turn the pressure regulator adjusting screw clockwise six complete turns. This adjustment provides a preliminary pressure setting of about 10.5" w.c. (2.6 kPa) for the LP regulator.
5. Check regulator setting either with a manometer or by clocking the gas meter.
6. Reinstall cap screw.

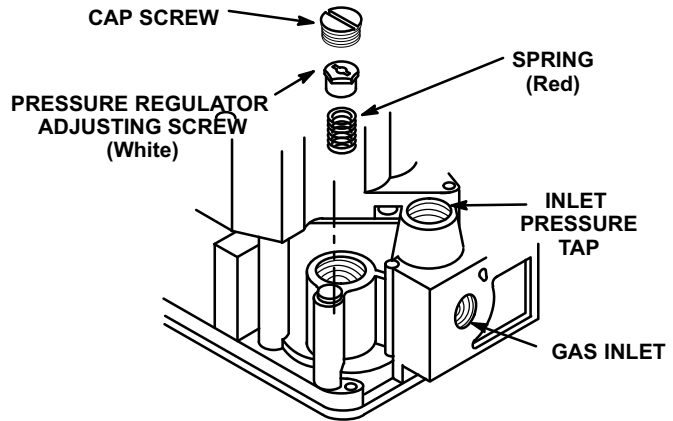

FIGURE 3

### Pressure Switch - Two-Stage Gas Valves

- 1- Install the nipple and pressure switch on the inlet pressure tap of the two-stage gas valve. Apply pipe sealer to at least the first three threads of nipple. See figure 4.

*NOTE-Compounds used on threaded joints of gas piping must be resistant to the action of LP/propane gas.*

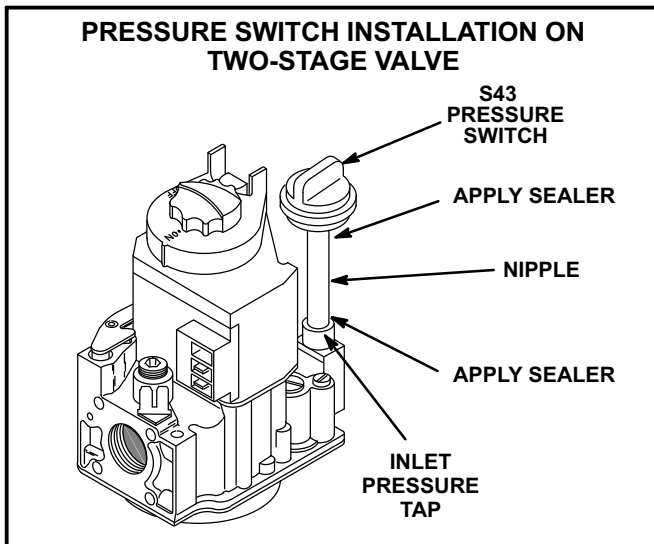

FIGURE 4

- 2- Locate J19/P19 combustion air blower connectors in divider panel between heat and compressor sections.
- 3- Disconnect J19/P19.
- 4- Install kit harness between disconnected plugs. Use the 3-wire harness (for Legacy) or the 4-wire harness (for current pole). Discard the unused harness See figure 5.
- 5- Locate S18 combustion air prove switch and disconnect wire labeled P1-5-S18. See figure 6.

- 6- Pull the wire through the division panel to the compressor section. Connect the wire to S43 LP low pressure switch on gas valve. See figure 6.
- 7- Connect the jumper wire provided in this kit to S43 pressure switch and route through division panel to heat section. Connect to S18 combustion air prove switch. See figure 6.

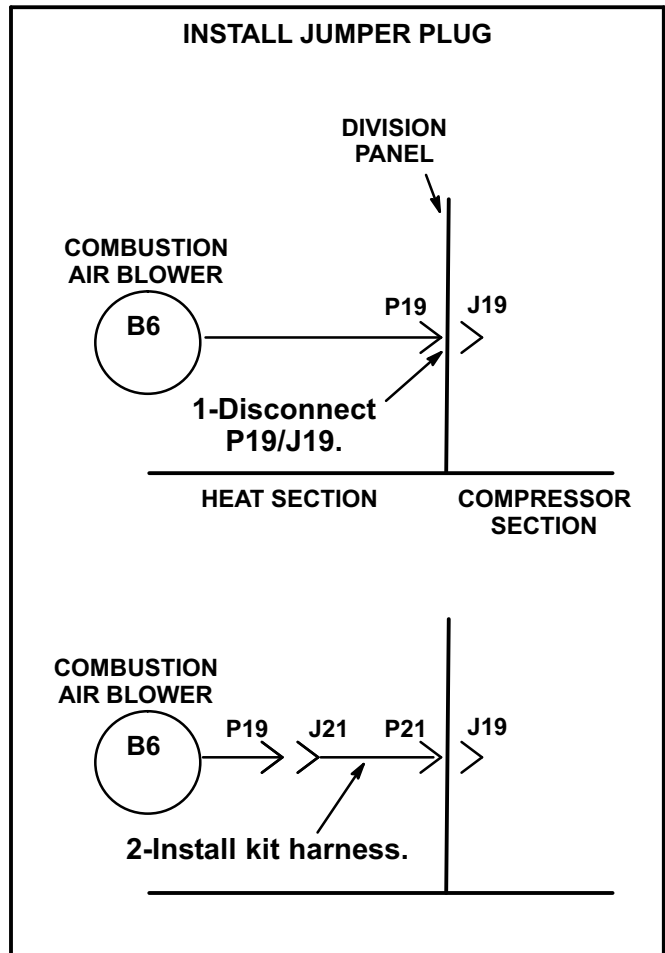
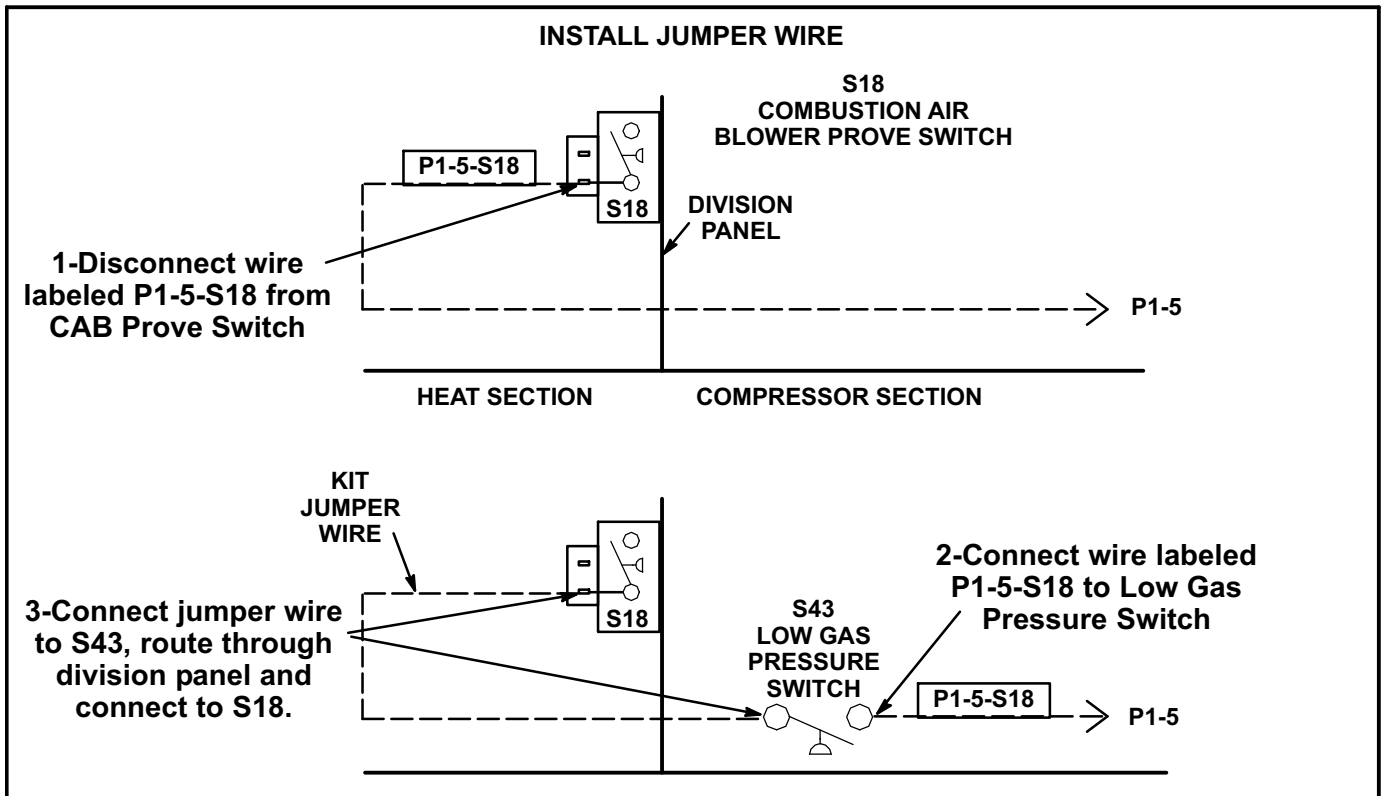

FIGURE 5



**FIGURE 6**

### Start-Up And Adjustments

- 1- Replace mullion between compressor and heat section.
- 2- Close heat section access panel.

#### A-To place unit in operation:

- 1- Turn main manual shut-off valve on.

## ⚠ WARNING



**Danger of explosion. Can cause injury or death. Do not attempt to light manually. Unit has a direct spark ignition system.**

- 2- Wait five minutes, then open manual knob on gas valve and replace compressor access panel.
- 3- Restore electrical supply to unit and set fan switch to "Auto" or "On." Move system selection switch to "Heat" and adjust thermostat setting above room temperature.
- 4- The combustion air blower will start and burners will light within 40 seconds.
- 5- If burners do not light first time (gas line not fully purged), ignition system will attempt to light two more times before locking out gas valve operation.
- 6- If lockout occurs, repeat steps 1, 2 and 3 above.

#### B-To shut down unit operation:

- 1- Set thermostat selection switch to "Off" position, remove compressor access panel and turn manual knob on gas valve to "Off" position.
- 2- Replace compressor access panel.

#### C-Heating Adjustment

Check gas line pressure with unit firing at maximum rate. A minimum of 10.8" w.c., and a maximum of 13.5" w.c. should be maintained. Manifold pressure is preset at :

- 10.5" w.c. for single-stage gas valves
- 10.5" w.c. for two-stage gas valves at high fire
- 5.1" w.c. for two-stage gas valves at low fire

No adjustment should be necessary. On multiple unit installations, each unit should be checked in sequence beginning with the one closest to the supply gas main and progressing to the one furthest from the main.

### Identifying Unit As LP Converted

- 1- Make a check mark in the appropriate box on the conversion plate corresponding to unit model number shown on nameplate. Affix appropriate conversion plate near unit nameplate.
- 2- Complete installer information on converter sticker and affix to vestibule panel.