

## ⚠ WARNING

Improper installation, adjustment, alteration, service or maintenance can cause property damage, personal injury or loss of life. Installation and service must be performed by a licensed professional HVAC installer or equivalent or service agency.

**RETAIN THESE INSTRUCTIONS FOR FUTURE REFERENCE**

### Table Of Contents

Dimensions .....	Page 2
Shipping and Packing List .....	Page 3
General .....	Page 3
Requirements .....	Page 3
Unit Support .....	Page 4
Duct Connection .....	Page 5
Rigging Unit For Lifting .....	Page 5
Horizontal Air Discharge .....	Page 5
Condensate Drains .....	Page 6
Electrical Connections .....	Page 8
Blower Operation and Adjustments .....	Page 9
Start-Up .....	Page 30
Defrost Control Board .....	Page 40
Service .....	Page 41

# INSTALLATION INSTRUCTIONS

<b>KHB024S/H</b>	(2-Ton)
<b>KHB030S</b>	(2-1/2-Ton)
<b>KHA036S</b>	(3-Ton)
<b>KHB036S/H</b>	(3-Ton)
<b>KHA048S</b>	(4-Ton)
<b>KHB048S/H</b>	(4-Ton)
<b>KHA060S</b>	(5-Ton)
<b>KHB060S/H</b>	(5-Ton)
<b>KHA072S</b>	(6-Ton)
<b>KHB074S</b>	(6-Ton)

HEAT PUMP PACKAGED UNITS  
 507349-03  
 1/2018  
 Supersedes 11/2016

## KH 024, 030, 036, 048, 060, 072, 074 PARTS ARRANGEMENT

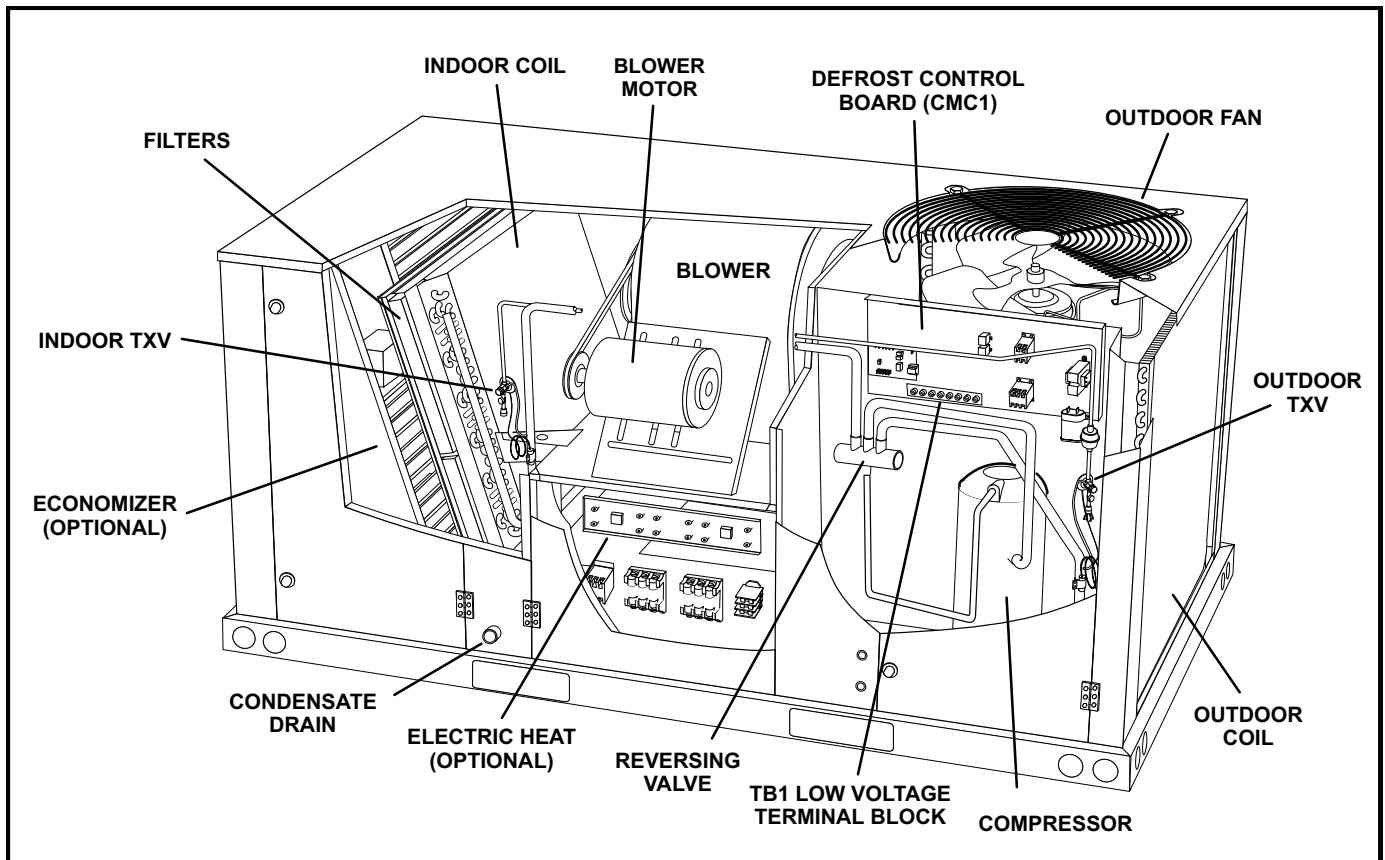

**KH 024, 030, 036, 048, 060, 072, 074 DIMENSIONS in (mm)**

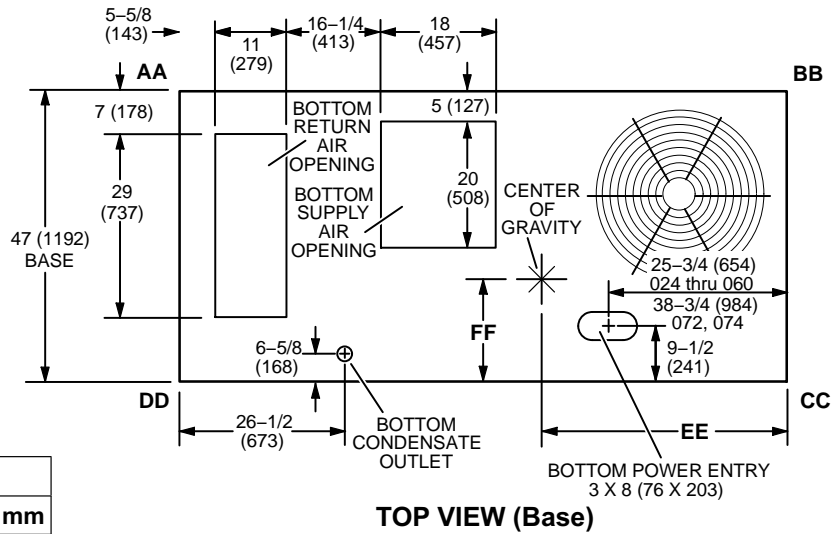

Model No.	A	
	in.	mm
KH 024-048, KH 060S	18-3/4	476
KHA060, 072, KHB060H, 074S	22-1/2	572

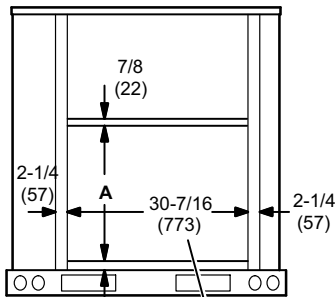

(Overall dimensions same as end view without economizer)  
 7/8 (22)  
 UNIT RETURN AIR DUCT OPENING WITH HORIZONTAL ECONOMIZER INSTALLED

**END VIEW**

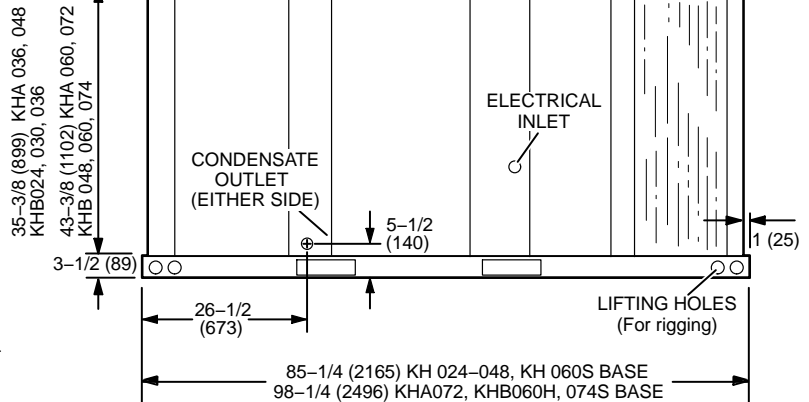

**SIDE VIEW**

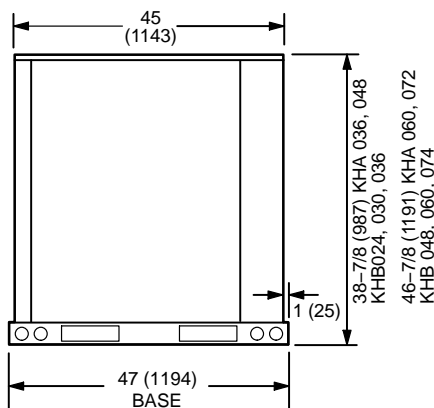

**END VIEW**

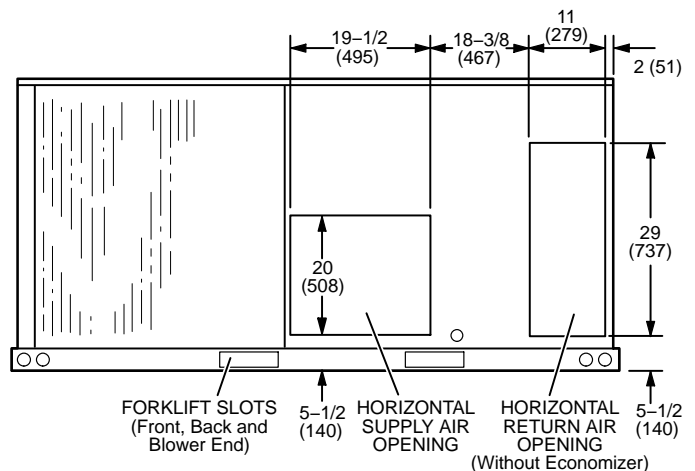

**BACK VIEW**

## Shipping and Packing List

**Package 1 of 1 contains:**

1 - Assembled unit

Check unit for shipping damage. Receiving party should contact last carrier immediately if shipping damage is found.

## General

These instructions are intended as a general guide and do not supersede local codes in any way. Authorities having jurisdiction should be consulted before installation.

KHA units have 3, 4, 5 and 6 ton cooling capacities. KHB standard efficiency units have 2, 2-1/2, 3, 4, 5 and 6-ton cooling capacities. KHB high efficiency units have 2, 3, 4 and 5 ton cooling capacities. Optional electric heat is available.

KHB high efficiency units have multi-tap, direct drive supply air blower and condenser fan motors. KHB high efficiency units are available equipped with a belt drive, two-speed, supply air blower. KHB high efficiency units will operate at lower speeds when cooling demand is low and increase to higher speeds when cooling demand is high.

Availability of units and options varies by brand.

## Requirements

The KH unit is ETL/CSA certified as a heat pump with cooling and with or without auxiliary electric heat for non-residential use only at the clearances to combustible materials as listed on the unit nameplate and in figure 1.

Installation of KH heat pumps must conform with standards in National Fire Protection Association (NFPA) "Standard for Installation of Air Conditioning and Ventilating Systems NFPA No. 90A," "Standard for Installation of Residence Type Warm Air Heating and Air conditioning Systems NFPA No. 90B," local municipal building codes and manufacturer's installation instructions.

The National Electric Code (ANSI/NFPA No. 70-1984) is available from:

National Fire Protection Association  
1 Batterymarch Park  
PO Box 9101  
Quincy, MA 02269-9101

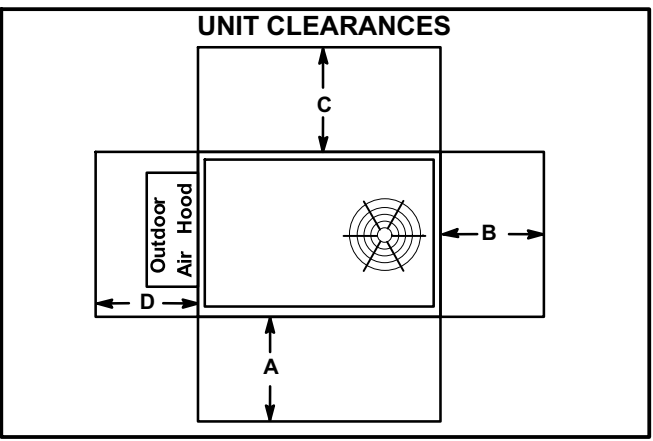

**FIGURE 1**

<sup>1</sup> Unit Clearance	A in. (mm)	B in. (mm)	C in. (mm)	D in. (mm)	Top Clearance
Service Clearance	36 (914)	36 (914)	36 (914)	36 (914)	Unobstructed
Minimum Operation Clearance	36 (914)	36 (914)	36 (914)	36 (914)	Unobstructed

Note - Entire perimeter of unit base requires support when elevated above mounting surface.

<sup>1</sup> **Service Clearance** - Required for removal of serviceable parts.  
**Minimum Operation Clearance** - Required clearance for proper unit operation.

⚠ **NOTICE**

**Roof Damage!**  
This system contains both refrigerant and oil. Some rubber roofing material may absorb oil, causing the rubber to swell. Bubbles in the rubber roofing material can cause leaks. Protect the roof surface to avoid exposure to refrigerant and oil during service and installation. Failure to follow this notice could result in damage to roof surface.

Installation of ETL/CSA certified units must also conform with current standard C273.5 "Installation Requirements for Heat Pumps" and applicable local codes. Authorities having jurisdiction should be consulted before installation.

Use of this unit as a construction heater or air conditioner is not recommended during any phase of construction. Very low return air temperatures, harmful vapors and operation of the unit with clogged or misplaced filters will damage the unit.

If this unit has been used for heating or cooling of buildings or structures under construction, the following conditions must be met or the warranty will be void:

- A room thermostat must control the unit. The use of fixed jumpers that will provide continuous heating or cooling is not allowed.
- A pre-filter must be installed at the entry to the return air duct.

- The return air duct must be provided and sealed to the unit.
- Return air temperature range between 55°F (13°C) and 80°F (27°C) must be maintained.
- Air filters must be replaced and pre-filter must be removed upon construction completion.
- The unit components, duct system, air filters and evaporator coil must be thoroughly cleaned following final construction clean-up.
- The unit operating conditions (including airflow, cooling operation, and heating operation) must be verified according to these installation instructions.

## ⚠ CAUTION

As with any mechanical equipment, contact with sharp sheet metal edges can result in personal injury. Take care while handling this equipment and wear gloves and protective clothing.

## ⚠ WARNING



Electric shock hazard and danger of explosion. Can cause injury, death or product or property damage. Turn off electrical power to unit before performing any maintenance or servicing operations on the unit.

## ⚠ IMPORTANT

The Clean Air Act of 1990 bans the intentional venting of refrigerant (CFC's and HCFC's) as of July 1, 1992. Approved methods of recovery, recycling or reclaiming must be followed. Fines and/or incarceration may be levied for non-compliance.

### Unit Support

*NOTE - Securely fasten roof frame to roof per local codes.*

## ⚠ CAUTION

To reduce the likelihood of supply / return air bypass and promote a proper seal with the RTU, duct work / duct drops / diffuser assemblies must be supported independently to the building structure.

### A - Downflow Discharge Application

#### Roof Mounting with C1CURB

- 1- The C1CURB roof mounting frame must be installed, flashed and sealed in accordance with the instructions provided with the frame.

- 2- The C1CURB roof mounting frame should be square and level to 1/16" per linear foot (5mm per linear meter) in any direction.

- 3- Duct must be attached to the roof mounting frame and not to the unit; supply and return plenums must be installed before setting the unit.

### Installer's Roof Mounting Frame

Many types of roof frames can be used to install the unit, depending upon different roof structures. Items to keep in mind when using the building frame or supports are:

- 1- The unit base is fully enclosed and insulated, so an enclosed frame is not required.

- 2- The frames or supports must be constructed with non-combustible materials and should be square and level to 1/16" per linear foot (5mm per linear meter) in any direction.

- 3- Frame or supports must be high enough to prevent any form of moisture from entering unit. Recommended minimum frame height is 14" (356mm).

- 4- Duct must be attached to the roof mounting frame and not to the unit. Supply and return plenums must be installed before setting the unit.

- 5- Units require support along all four sides of unit base. Supports must be constructed of steel or suitably treated wood materials.

*NOTE-When installing unit on a combustible surface for downflow discharge applications, the C1CURB roof mounting frame is required.*

### B - Horizontal Discharge Applications

- 1- Units which are equipped with an optional economizer and installed in horizontal airflow applications must use a horizontal conversion kit.

- 2- Specified installation clearances must be maintained when installing units. Refer to figure 1.

- 3- Top of support slab should be at least 4" (102mm) above the finished grade and located so no run-off water from higher ground can collect around the unit.

- 4- Units require support along all four sides of unit base. Supports must be constructed of steel or suitably treated wood materials.

## Duct Connection

All exterior ducts, joints, and openings in roof or building walls must be insulated and weatherproofed with flashing and sealing compounds in accordance with applicable codes. Any duct passing through an unconditioned space must be insulated.

## **! CAUTION**

**In downflow applications, do not drill or punch holes in base of unit. Leaking in roof may occur if unit base is punctured.**

## Rigging Unit For Lifting

- 1- Detach wooden base protection before rigging.
- 2- Remove all six base protection brackets before setting unit.
- 3- Connect rigging to the unit base using both holes in each corner. See figure 2.
- 4- All panels must be in place for rigging.
- 5- Place field-provided H-style pick in place just above top edge of unit. Frame must be of adequate strength and length. (H-style pick prevents damage to unit.)

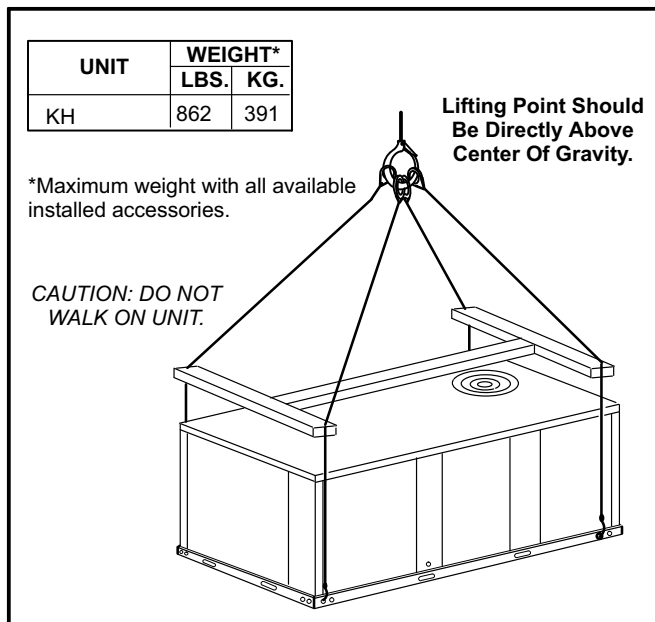

FIGURE 2

## Horizontal Air Discharge

Unit is shipped with panels covering the horizontal supply and return air openings. Remove horizontal covers and place over downflow openings for horizontal air discharge. See figure 3. Secure in place with sheet metal screws.

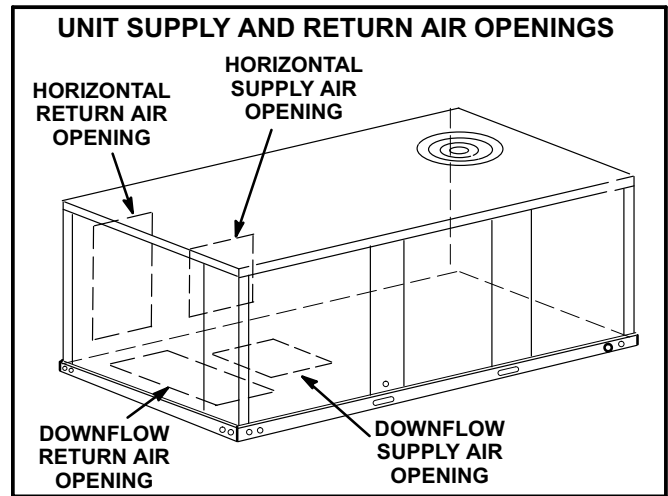

FIGURE 3

*Units Equipped With An Optional Economizer -*

- 1- Remove the horizontal supply air cover and position over the downflow supply air opening. Secure with sheet metal screws.
- 2- Leave the horizontal return air cover in place.
- 3- Locate the separately ordered horizontal air discharge kit. Place the kit panel over the downflow return air opening.
- 4- Remove and retain the barometric relief dampers and lower hood.
- 5- Install return air duct beneath outdoor air intake. See figure 4. Install barometric relief damper in lower hood and install in duct as shown in figure 4.

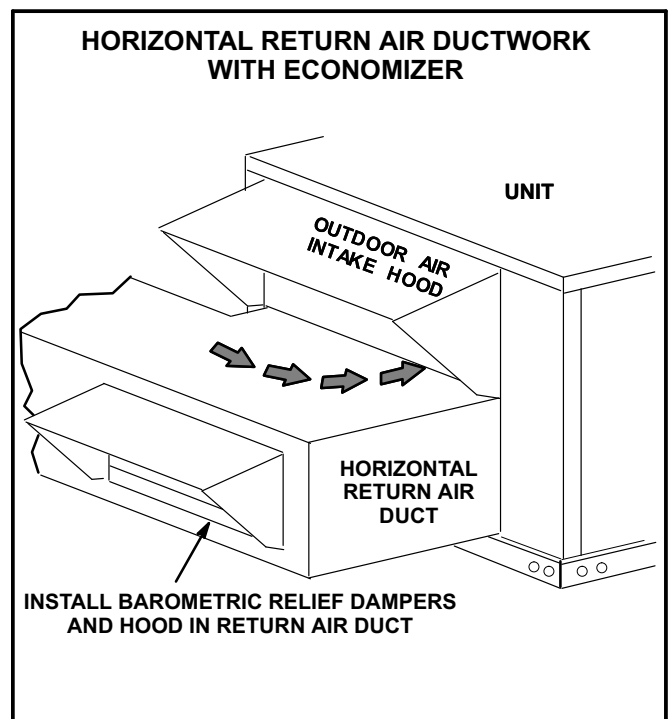

FIGURE 4

## Condensate Drains

Make drain connection to the 1" N.P.T. drain coupling provided on unit.

*Note - The drain pan is made with a glass reinforced engineered plastic capable of withstanding typical joint torque but can be damaged with excessive force. Tighten pipe nipple hand tight and turn an additional quarter turn.*

A trap must be installed between drain connection and an open vent for proper condensate removal. See figure 5 or 6. It is sometimes acceptable to drain condensate onto the roof or grade; however, a tee should be fitted to the trap to direct condensate downward. The condensate line must be vented. Check local codes concerning condensate disposal. Refer to pages 1 and 2 for condensate drain location.

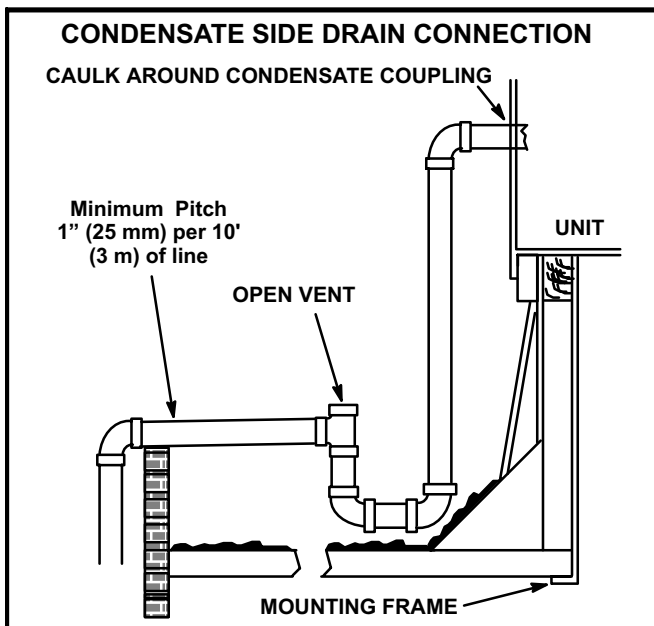

FIGURE 5

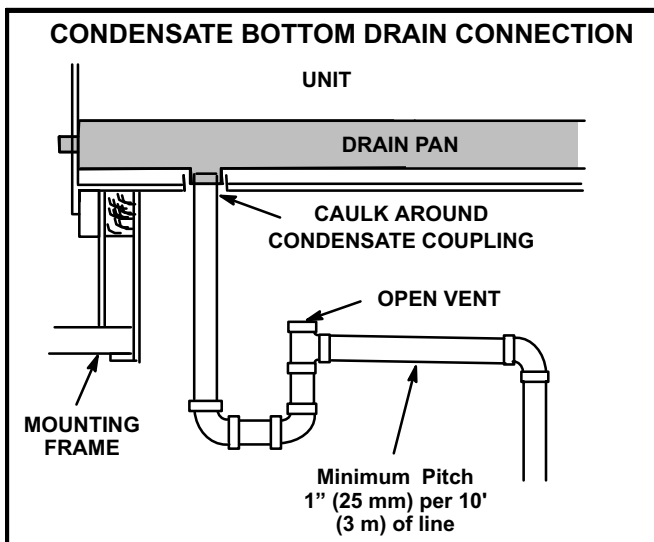

FIGURE 6

Units are shipped with the drain coupling facing the front of the unit. Condensate can be drained from the back or bottom of the unit with the following modifications. The unit can be installed in either downflow or horizontal air discharge regardless of condensate drain location.

### Rear Drain Connection

- 1- Remove the condensate drain mullion. See figure 7. Remove the two panels on each side of the mullion.

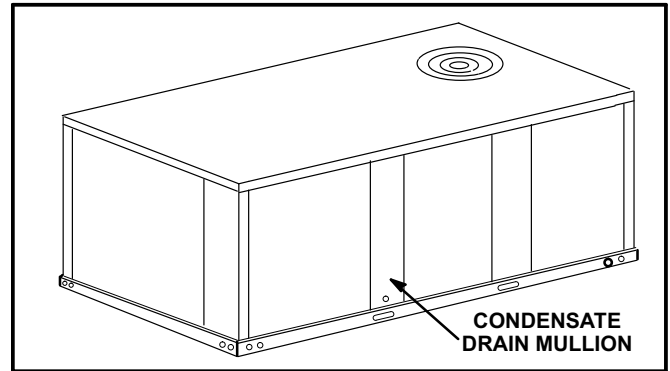

FIGURE 7

If the unit has hinged panels, two hinge screws must be removed in addition to the mullion screws. See figure 8.

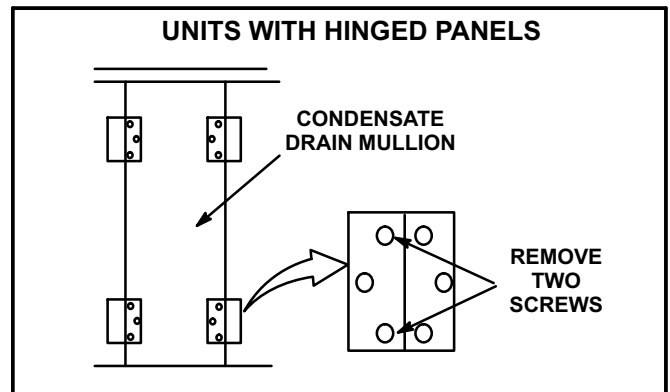

FIGURE 8

- 2- Lift the front edge of the drain pan and slide pan out of unit. See figure 9.

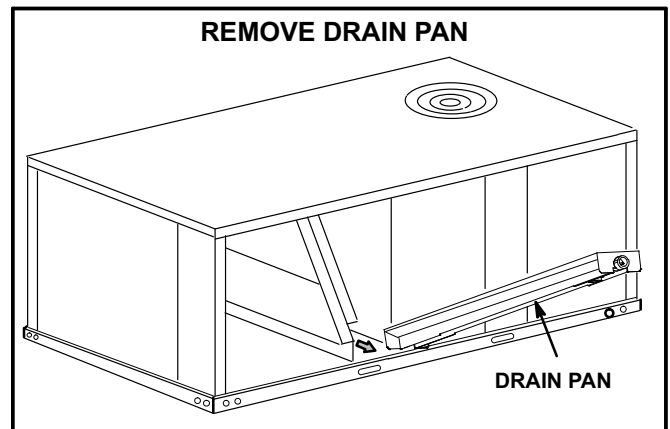

FIGURE 9

- 3- Make sure the cap over the unit bottom drain hole is secure.
- 4- Rotate the drain pan until the downward slope is toward the back of the unit. Slide the drain pan back into the unit. Be careful not to dislodge the cap over the bottom drain hole.
- 5- From the back side of the unit, pull the drain pan coupling through the rear condensate opening.
- 6- Replace the condensate drain mullion and reinstall screws. Reinstall access doors.

### Bottom Drain Connection

- 1- Remove the condensate drain mullion. See figure 7.  
If the unit has hinged panels, two hinge screws must be removed in addition to the mullion screws. See figure 8.
- 2- Lift the front edge of the drain pan and slide pan out of unit. See figure 9.
- 3- Turn the drain pan upside down and drill a pilot hole through the bottom of the drain pan in the center of the coupling. See figure 10.
- 4- From the inside of the pan, use a Vari-Bit® bit to enlarge the hole to 7/8". Do not damage coupling threads.
- 5- Remove the cap over the unit bottom drain hole.
- 6- Slide the drain pan back into the unit.

- 7- From the back side of the unit, pull the drain pan coupling through the rear condensate opening.
- 8- From the front side of the unit, move the drain pan until the bottom coupling settles into the unit bottom drain opening. Once in place, check to make sure the coupling is still positioned through the rear condensate drain hole.
- 9- Use a field-provided 1" plug to seal side drain connection.
- 10- Replace the condensate drain mullion and reinstall screws. Reinstall access doors.

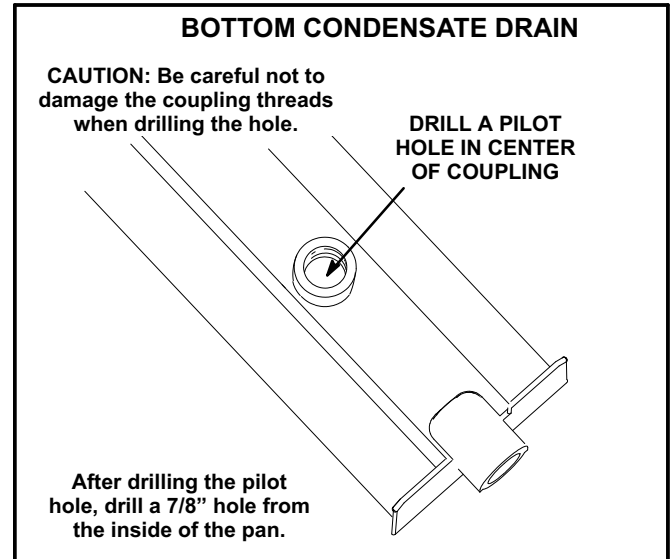

**FIGURE 10**

## Electrical Connections

### POWER SUPPLY

Do not apply power or close disconnect switch until installation is complete. Refer to start-up directions. Refer closely to unit wiring diagram.

Refer to unit nameplate for minimum circuit ampacity and maximum fuse size.

- 1- Units are factory-wired for 230,460,575 volt supply. **For 208V supply**, remove the insulated terminal cover from the 208V terminal on the control transformer. Move the wire from the transformer 240V terminal to the 208V terminal. Place the insulated terminal cover on the unused 240V terminal.
- 2- Route power through the bottom power entry area and connect to TB2 or factory-installed circuit breaker or disconnect. Secure power wiring with factory-installed wire ties provided in control box. See unit wiring diagram.

### CONTROL WIRING

#### A - Thermostat Location

Room thermostat mounts vertically on a standard 2" X 4" handy box or on any non-conductive flat surface.

Locate thermostat approximately 5 feet (1524 mm) above the floor in an area with good air circulation at average temperature. Avoid locating the room thermostat where it might be affected by:

- drafts or dead spots behind doors and in corners
- hot or cold air from ducts
- radiant heat from sun or appliances
- concealed pipes and chimneys

**IMPORTANT** - Unless field thermostat wires are rated for maximum unit voltage, they must be routed away from line voltage wiring. Use wire ties located near the lower left corner of the controls hat section to secure thermostat cable.

#### B - Control Wiring

- 1- Route thermostat cable or wires from subbase to control area above compressor (refer to unit dimensions to locate bottom and side power entry). Use 18 AWG wire for all applications using remotely installed electro-mechanical and electronic thermostats.
- 2- Install thermostat assembly in accordance with instructions provided with thermostat.
- 3- Connect thermostat wiring to TB1 terminal control board on the lower side of the controls hat section. Wire as shown in figure 11 for electro-mechanical and electronic thermostats. If using other temperature control devices or energy management systems see instructions and wiring diagram provided by manufacturer.

**IMPORTANT**-Terminal connections at the wall plate or subbase must be made securely. Loose control wire connections may allow unit to operate but not with proper response to room demand.

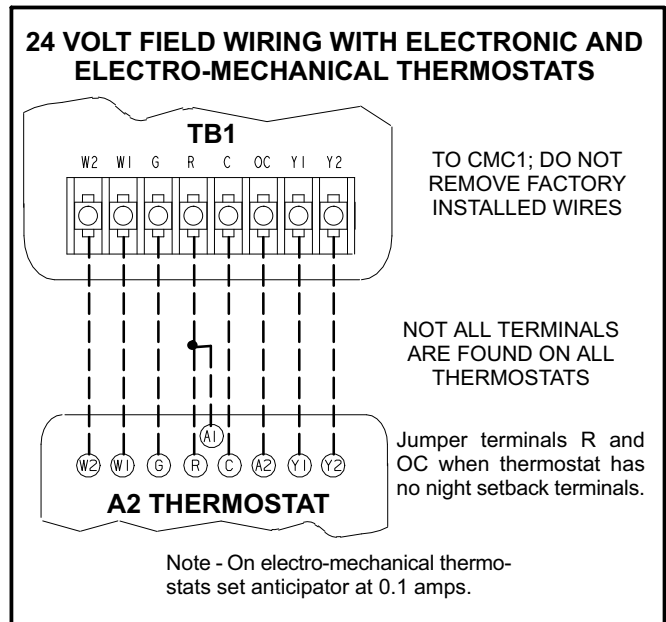

FIGURE 11



## Blower Operation and Adjustments

Units are equipped with direct or belt drive blowers; available drive varies by model.

KHB high efficiency and KHB074 units are equipped with either two-stage belt drive blowers or direct drive, multi-tap motors. The blower will operate at high speed with a Y2 thermostat demand and low speed with a Y1 thermostat demand. Low speed operation delivers approximately  $\frac{2}{3}$  of the air volume of high speed. Two-speed blower operation results in lower energy consumption.

### ⚠ IMPORTANT

**Three phase scroll compressors must be phased sequentially for correct compressor and blower rotation. Follow "COOLING START-UP" section of installation instructions to ensure proper compressor and blower operation.**

#### A - Blower Operation

- 1- Set thermostat or temperature control device fan switch to **AUTO** or **ON**. With fan switch in **ON** position, blower will operate continuously. With fan switch in **AUTO** position, the blower will cycle with demand.
- 2- Blower and entire unit will be off when thermostat or temperature control device system switch is in **OFF** position.

#### B - Determining Unit CFM - Direct Drive Blowers

- 1- The following measurements must be made with air filters in place.
- 2- With all access panels in place, measure static pressure external to unit (from supply to return). Add any additional air resistance for options and accessories shown on page 29.
- 3- Use figure 12 to determine the factory set blower speed(s) for standard efficiency units and figure 13 for high efficiency units.

- 4- Use page 13 through 19, the measured static pressure, and the factory-set blower speed to determine CFM.

#### 5- Standard Efficiency Units -

If CFM is lower than the design specified CFM, move the lead from speed tap 3 or 4 to speed tap 2. See figure 14. Refer to table 1 for minimum airflow when electric heat is installed.

*Note - For 460/575V units, remove the isolation lead from speed tap 2 before moving the wire to speed tap 2. Tape the exposed end of the isolation lead and secure away from other components.*

#### High Efficiency Units -

If low speed CFM is lower than the design specified CFM, move the lead marked *B3-Low* from the green wire to the white wire. See figure 13. If high speed CFM is lower than the design specified CFM, move the lead marked *B3-High* from the blue wire to the black (med. High) or brown (high) wire. Refer to table 1 for minimum airflow when electric heat is installed.

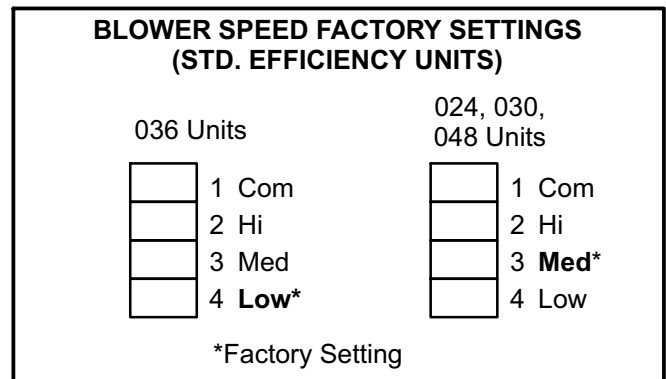

**FIGURE 12**

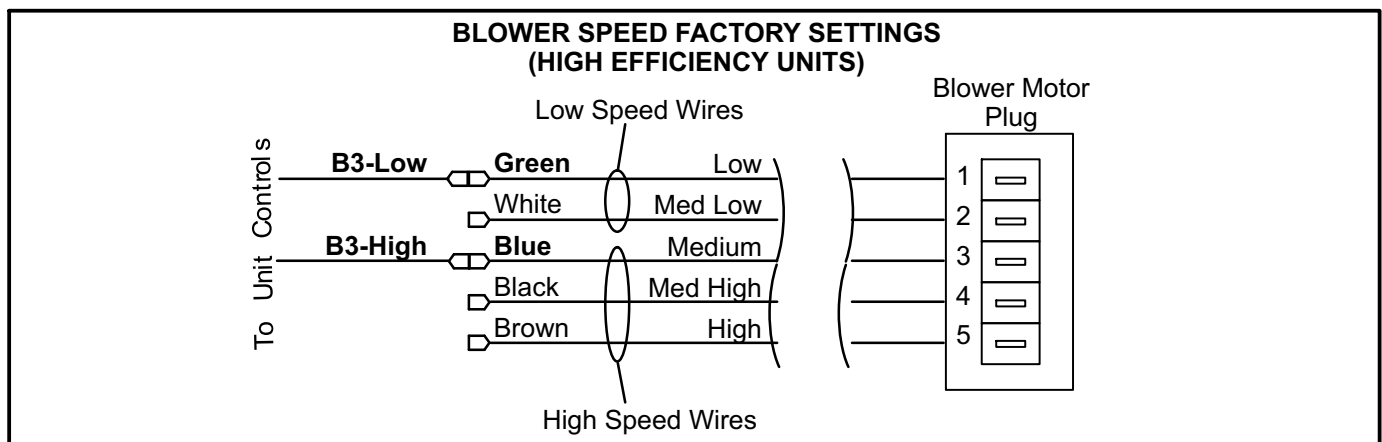

**FIGURE 13**

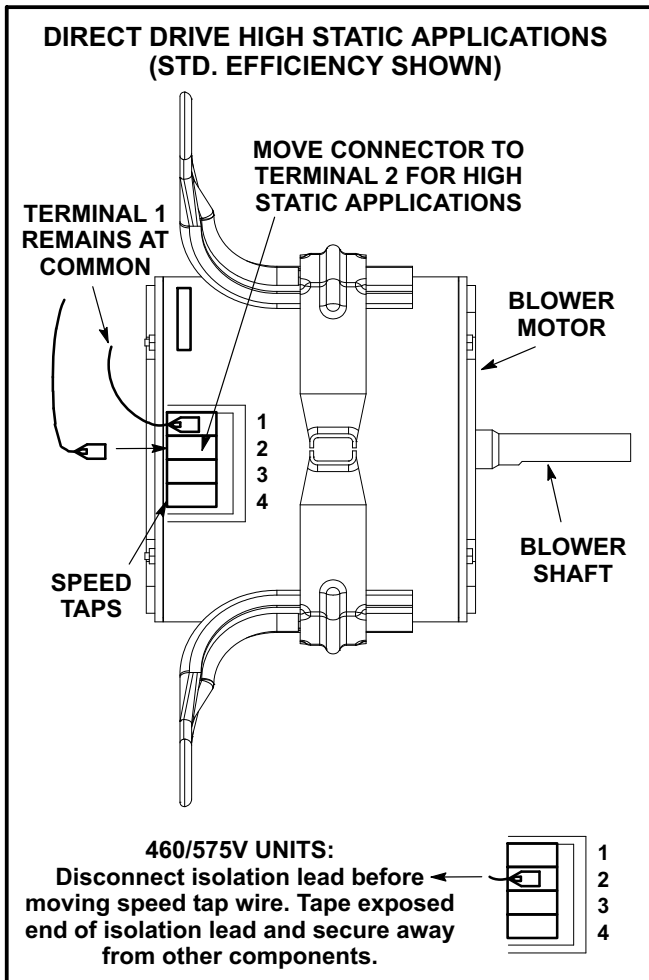

**FIGURE 14**

**TABLE 1  
MINIMUM AIRFLOW  
KH (BELT DRIVE) UNITS WITH ELECTRIC HEAT**

kW	CFM	
	Downflow	Horizontal
30	2250	2050
22.5	1750	1800
15	1250	1350
7.5	1050	1200

Direct drive units with electric heat (5.0-22.5kW) can operate on low speed up to 0.6" w.g. maximum static pressure.

**C - Determining Unit CFM - Belt Drive Blowers**

**IMPORTANT** - KHB074 blower (G thermostat) **CFM MUST BE ADJUSTED IN HIGH SPEED**. Disconnect factory-installed J350 low speed connector from P350. Connectors are located near the bottom of the control box. Connect J351 high speed connector to P350. Once blower CFM is set, J350 can be reconnected to operate the blower on low during ventilation only demands. See table 2.

**TABLE 2  
TWO-SPEED BLOWER OPERATION  
KHB074 UNITS**

Thermostat	Blower Speed
G (P350/J350)*	Low
G (P350/J351)	High
W1	High
W2	High
Y1	Low
Y2	High

\*Factory-installed jack/plug connection.

- 1- The following measurements must be made with air filters in place.
- 2- With all access panels in place, measure static pressure external to unit (from supply to return). Blower performance data is based on static pressure readings taken in locations shown in figure 15.

*Note - Static pressure readings can vary if not taken where shown.*

- 3- Measure the indoor blower wheel RPM.
- 4- Referring to pages 20 through 28, use static pressure and RPM readings to determine unit CFM. Use page 29 when installing units with any of the options or accessories listed. Refer to table 1 for minimum airflow when electric heat is installed.

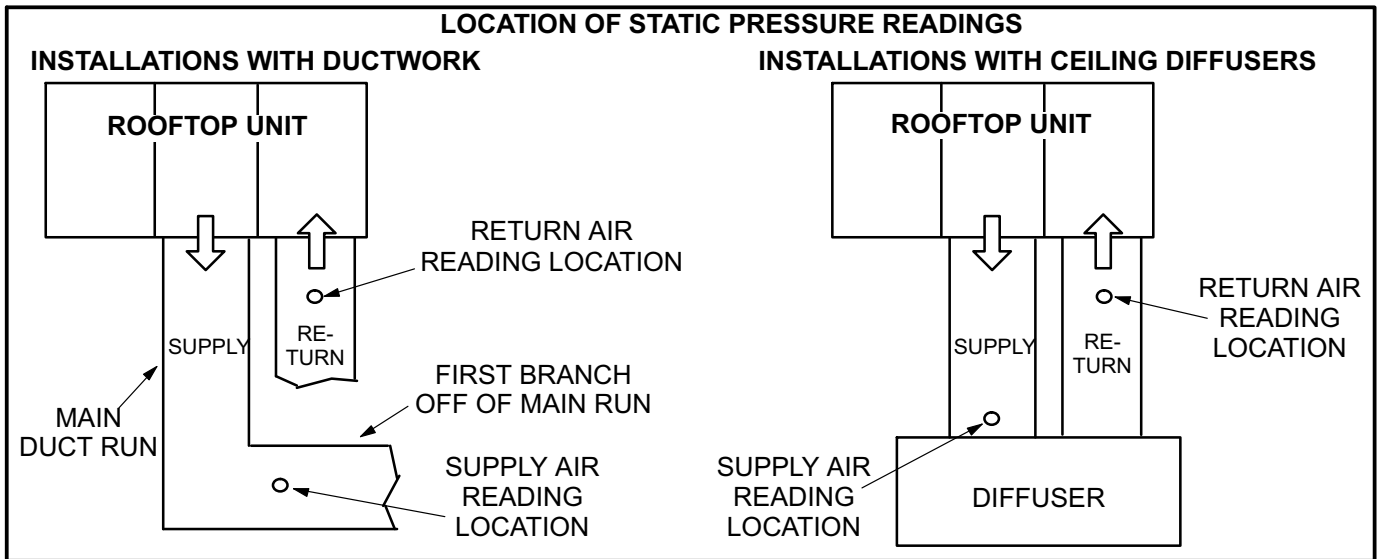

**FIGURE 15**

5- The blower RPM can be adjusted at the motor pulley. Loosen Allen screw and turn adjustable pulley clockwise to increase CFM. Turn counterclockwise to decrease CFM. See figure 17. Do not exceed minimum and maximum number of pulley turns as shown in table 3.

**TABLE 3  
MINIMUM AND MAXIMUM PULLEY ADJUSTMENT**

Belt	Min. Turns Open	Maxi. Turns Open
A Section	No minimum	5

6- *KHB074 Unit Only* -  
If low speed during ventilation is desired, replace J351 connector with J350.

**D - Blower Belt Adjustment**

Maximum life and wear can be obtained from belts only if proper pulley alignment and belt tension are maintained. Tension new belts after a 24-48 hour period of operation. This will allow belt to stretch and seat grooves. Make sure blower and motor pulley are aligned as shown in figure 16.

1- Loosen four bolts securing motor base to mounting frame. See figure 17.

2- *To increase belt tension* -  
Slide blower motor downward to tighten the belt. This increases the distance between the blower motor and the blower housing.

*To loosen belt tension* -  
Slide blower motor upward to loosen the belt. This decreases the distance between the blower motor and the blower housing.

3- Tighten four bolts securing motor base to the mounting frame.

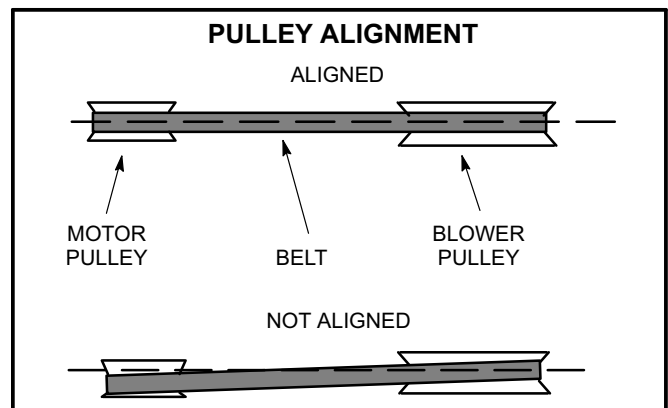

**FIGURE 16**

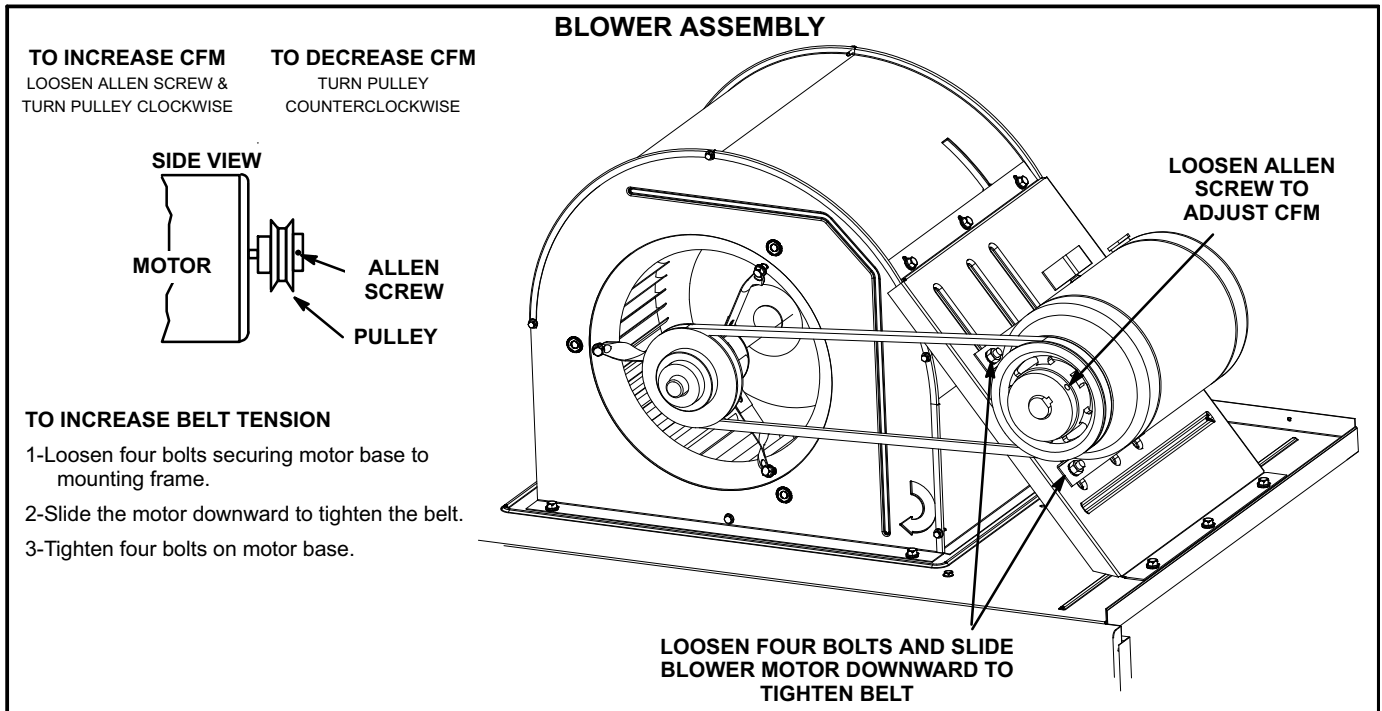

**FIGURE 17**

**E - Check Belt Tension**

Overtensioning belts shortens belt and bearing life. Check belt tension as follows:

- 1- Measure span length X. See figure 18.
- 2- Apply perpendicular force to center of span (X) with enough pressure to deflect belt 1/64" for every inch of span length or 1.5mm per 100mm of span length.

Example: Deflection distance of a 40" span would be 40/64" or 5/8".

Example: Deflection distance of a 400mm span would be 6mm.

- 3- Measure belt deflection force. For a used belt, the deflection force should be 5 lbs. (35kPa). A new belt deflection force should be 7 lbs. (48kPa).

A force below these values indicates an undertensioned belt. A force above these values indicates an overtensioned belt.

**F - Field-Furnished Blower Drives**

For field-furnished blower drives, use page 20 through 28 to determine BHP and RPM required. Reference page 29 for drive kit specifications and table 4 for manufacturer's drive component numbers.

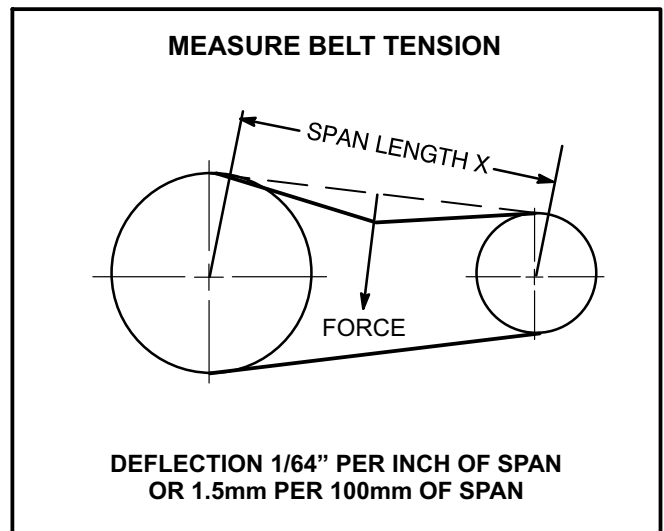

**FIGURE 18**

## BLOWER DATA - DIRECT DRIVE - KHB024-030 - STANDARD EFFICIENCY

BLOWER TABLE INCLUDES RESISTANCE FOR BASE UNIT ONLY WITH DRY INDOOR COIL AND AIR FILTERS IN PLACE.

FOR ALL UNITS ADD:

1 - Any factory installed options air resistance (economizer, wet coil, etc.) See page 29.

2 - Any field installed accessories air resistance (electric heat, duct resistance, diffuser, etc.) See page 29.

External Static Pressure (in. w.g.)	Air Volume (cfm) at Various Blower Speeds					
	208 VOLTS			230 VOLTS		
	High	Medium	Low	High	Medium	Low
<b>2 and 2.5 Ton Standard Efficiency (Downflow)</b>			<b>KHB024S and KHB030S</b>			
0.0	1199	928	838	1379	1085	877
0.1	1229	926	813	1409	1086	872
0.2	1206	928	782	1367	1094	850
0.3	1183	881	742	1350	1047	820
0.4	1159	843	686	1321	1009	783
0.5	1136	812	643	1282	981	762
0.6	1103	766	569	1242	921	705
0.7	1046	728	496	1195	888	625
0.8	953	648	432	1134	792	583
0.9	909	584	335	1037	738	492
1.0	783	465	247	926	592	411
<b>2 and 2.5 Ton Standard Efficiency (Horizontal)</b>			<b>KHB024S and KHB030S</b>			
0.0	1152	909	801	1325	1063	838
0.1	1152	893	770	1321	1048	826
0.2	1136	866	734	1288	1021	798
0.3	1104	826	697	1260	982	771
0.4	1072	787	643	1222	942	734
0.5	1041	747	589	1175	903	698
0.6	1009	707	534	1137	850	662
0.7	946	654	467	1081	797	588
0.8	861	588	396	1024	718	535
0.9	798	508	319	911	642	468
1.0	715	443	237	846	564	394

**BLOWER DATA - DIRECT DRIVE - KHA/KHB036, KHA048 - STANDARD EFFICIENCY**

**BLOWER TABLE INCLUDES RESISTANCE FOR BASE UNIT ONLY WITH DRY INDOOR COIL AND AIR FILTERS IN PLACE.**

FOR ALL UNITS ADD:

1 - Any factory installed options air resistance (economizer, wet coil, etc.) See page 29.

2 - Any field installed accessories air resistance (electric heat, duct resistance, diffuser, etc.) See page 29.

External Static Pressure (in. w.g.)	Air Volume (cfm) at Various Blower Speeds								
	208 VOLTS			230 VOLTS			460/575 VOLTS		
	High	Medium	Low	High	Medium	Low	High	Medium	Low
<b>3 and 4 Ton Standard Efficiency (Downflow)</b>					<b>KHA/KHB036S and KHA048S</b>				
0.0	1938	1552	1119	2167	1772	1317	2136	1716	1212
0.1	1992	1586	1128	2167	1780	1315	2104	1728	1208
0.2	1915	1592	1137	2100	1792	1307	2052	1684	1197
0.3	1865	1536	1083	2043	1735	1266	1994	1647	1172
0.4	1813	1495	1033	1986	1678	1204	1918	1597	1134
0.5	1762	1444	976	1909	1621	1164	1861	1534	1096
0.6	1694	1391	899	1814	1535	1082	1765	1485	1059
0.7	1609	1331	817	1718	1478	1000	1689	1410	996
0.8	1471	1220	730	1603	1364	918	1613	1335	920
0.9	1368	1066	522	1488	1250	755	1498	1235	848
1.0	1108	869	402	1259	1021	640	1345	1036	763
<b>3 and 4 Ton Standard Efficiency (Horizontal)</b>					<b>KHA/KHB036S and KHA048S</b>				
0.0	1862	1520	1070	2082	1736	1259	2085	1745	1247
0.1	1867	1530	1069	2031	1717	1246	2070	1744	1257
0.2	1804	1485	1067	1978	1672	1227	2016	1690	1225
0.3	1741	1440	1018	1907	1627	1190	1944	1643	1192
0.4	1677	1396	968	1837	1567	1128	1890	1596	1160
0.5	1614	1329	894	1749	1492	1066	1800	1533	1111
0.6	1550	1284	844	1660	1417	1016	1727	1455	1062
0.7	1455	1195	769	1554	1327	941	1655	1377	996
0.8	1329	1106	670	1448	1237	842	1511	1283	865
0.9	1202	927	496	1307	1087	718	1403	1190	784
1.0	1012	828	385	1150	973	613	1222	1002	670

## BLOWER DATA - DIRECT DRIVE - KHB048 - STANDARD EFFICIENCY

**BLOWER TABLE INCLUDES RESISTANCE FOR BASE UNIT ONLY WITH DRY INDOOR COIL AND AIR FILTERS IN PLACE.**

FOR ALL UNITS ADD:

1 - Any factory installed options air resistance (economizer, wet coil, etc.) See page 29.

2 - Any field installed accessories air resistance (electric heat, duct resistance, diffuser, etc.) See page 29.

External Static Pressure (in. w.g.)	Air Volume (cfm) at Various Blower Speeds								
	208 VOLTS			230 VOLTS			460/575 VOLTS		
	High	Medium	Low	High	Medium	Low	High	Medium	Low
<b>3 and 4 Ton Standard Efficiency (Downflow)</b>									<b>KHB048S</b>
0.0	1951	1542	1098	2139	1542	1271	2139	1542	1271
0.1	1918	1526	1081	2105	1526	1261	2105	1526	1261
0.2	1877	1508	1062	2054	1508	1238	2054	1508	1238
0.3	1814	1448	1026	1986	1448	1196	1986	1448	1196
0.4	1752	1407	990	1918	1407	1154	1918	1407	1154
0.5	1689	1347	936	1826	1347	1099	1826	1347	1099
0.6	1605	1286	864	1735	1286	1043	1735	1286	1043
0.7	1500	1206	774	1644	1206	932	1644	1206	932
0.8	1375	1085	---	1461	1085	---	1461	1085	---
0.9	1202	---	---	---	---	---	---	---	---
1.0	---	---	---	---	---	---	---	---	---
<b>3 and 4 Ton Standard Efficiency (Horizontal)</b>									<b>KHB048S</b>
0.0	1901	1506	1079	2072	1718	1249	2072	1718	1249
0.1	1855	1478	1069	2026	1686	1238	2026	1686	1238
0.2	1800	1458	1049	1969	1644	1206	1969	1644	1206
0.3	1744	1396	1012	1908	1601	1161	1908	1601	1161
0.4	1687	1346	936	1847	1530	1115	1847	1530	1115
0.5	1630	1296	886	1755	1460	1047	1755	1460	1047
0.6	1546	1222	811	1663	1403	1002	1663	1403	1002
0.7	1461	1147	735	1572	1290	910	1572	1290	910
0.8	1347	1073	660	1419	1205	820	1419	1205	820
0.9	1178	874	560	1296	1006	683	1296	1006	683
1.0	954	624	358	1129	---	496	1129	---	496

**BLOWER DATA - DIRECT DRIVE - HIGH EFFICIENCY****2 TON****BLOWER TABLE INCLUDES RESISTANCE FOR BASE UNIT ONLY WITH DRY INDOOR COIL AND AIR FILTERS IN PLACE.**

FOR ALL UNITS ADD:

1 - Any factory installed options air resistance (economizer, wet coil, etc.) See page 29.

2 - Any field installed accessories air resistance (electric heat, duct resistance, diffuser, etc.) See page 29.

External Static Pressure in. w.g.	Air Volume at Specific Blower Taps (cfm)				
	Tap 1	Tap 2	Tap 3	Tap 4	Tap 5
<b>DOWNFLOW</b>					<b>KHB024H4E</b>
0.0	635	825	918	1121	1336
0.1	547	763	861	1071	1290
0.2	433	699	806	1031	1253
0.3	371	636	749	986	1212
0.4	280	559	677	927	1166
0.5	217	481	605	868	1120
0.6	---	---	548	819	1071
0.7	---	---	491	773	1029
0.8	---	---	442	714	983
0.9	---	---	393	653	929
1.0	---	---	---	604	879
<b>HORIZONTAL</b>					<b>KHB024H4E</b>
0.0	602	815	908	1096	1302
0.1	509	750	852	1057	1263
0.2	413	689	793	1007	1227
0.3	340	625	736	964	1189
0.4	266	561	679	918	1142
0.5	220	501	620	864	1100
0.6	---	---	560	809	1061
0.7	---	---	500	752	1015
0.8	---	---	444	706	964
0.9	---	---	390	661	913
1.0	---	---	352	612	872



**BLOWER DATA - DIRECT DRIVE - HIGH EFFICIENCY****3 TON****BLOWER TABLE INCLUDES RESISTANCE FOR BASE UNIT ONLY WITH DRY INDOOR COIL AND AIR FILTERS IN PLACE.**

FOR ALL UNITS ADD:

1 - Any factory installed options air resistance (economizer, wet coil, etc.) See page 29.

2 - Any field installed accessories air resistance (electric heat, duct resistance, diffuser, etc.) See page 29.

External Static Pressure in. w.g.	Air Volume at Specific Blower Taps (cfm)					
	Tap 1	Tap 2	Tap 3	Tap 4	Tap 5	
<b>DOWNFLOW</b>						<b>KHB036H4E</b>
0.0	893	1035	1375	1600	1840	
0.1	838	965	1330	1574	1780	
0.2	768	895	1277	1543	1748	
0.3	705	800	1253	1505	1712	
0.4	645	750	1200	1473	1677	
0.5	575	690	1150	1435	1638	
0.6	---	---	1095	1390	1608	
0.7	---	---	1052	1345	1577	
0.8	---	---	1004	1302	1528	
0.9	---	---	950	1260	1491	
1.0	---	---	900	1218	1455	
<b>HORIZONTAL</b>						<b>KHB036H4E</b>
0.0	900	1045	1379	1599	1810	
0.1	828	970	1305	1549	1749	
0.2	777	900	1264	1504	1718	
0.3	702	800	1216	1479	1677	
0.4	635	750	1173	1434	1649	
0.5	553	685	1131	1399	1622	
0.6	---	---	1078	1359	1577	
0.7	---	---	1038	1315	1544	
0.8	---	---	986	1280	1509	
0.9	---	---	933	1236	1471	
1.0	---	---	885	1196	1438	

**BLOWER DATA - DIRECT DRIVE - HIGH EFFICIENCY****4 TON****BLOWER TABLE INCLUDES RESISTANCE FOR BASE UNIT ONLY WITH DRY INDOOR COIL AND AIR FILTERS IN PLACE.**

FOR ALL UNITS ADD:

1 - Any factory installed options air resistance (economizer, wet coil, etc.) See page 29.

2 - Any field installed accessories air resistance (electric heat, duct resistance, diffuser, etc.) See page 29.

External Static Pressure in. w.g.	Air Volume at Specific Blower Taps (cfm)				
	Tap 1	Tap 2	Tap 3	Tap 4	Tap 5
<b>DOWNFLOW</b>					<b>KHB048H4E</b>
0.0	1225	1310	1561	2015	2168
0.1	1167	1254	1514	1995	2143
0.2	1112	1203	1473	1977	2126
0.3	1052	1145	1424	1942	2097
0.4	1000	1098	1387	1917	2078
0.5	939	1040	1343	1888	2049
0.6	894	996	1300	1854	2020
0.7	840	941	1250	1819	1991
0.8	780	883	1201	1787	1952
0.9	734	839	1159	1749	1914
1.0	681	784	1115	1704	1856
<b>HORIZONTAL</b>					<b>KHB048H4E</b>
0.0	1185	1265	1504	1983	2120
0.1	1130	1213	1467	1957	2098
0.2	1085	1171	1432	1932	2077
0.3	1035	1125	1395	1906	2054
0.4	978	1069	1347	1870	2023
0.5	929	1023	1304	1841	1992
0.6	880	977	1267	1811	1962
0.7	822	920	1224	1776	1931
0.8	764	863	1175	1740	1900
0.9	718	820	1133	1710	1869
1.0	549	712	1096	1652	1772

**BLOWER DATA - DIRECT DRIVE - HIGH EFFICIENCY****5 TON****BLOWER TABLE INCLUDES RESISTANCE FOR BASE UNIT ONLY WITH DRY INDOOR COIL AND AIR FILTERS IN PLACE.**

FOR ALL UNITS ADD:

1 - Any factory installed options air resistance (economizer, wet coil, etc.) See page 29.

2 - Any field installed accessories air resistance (electric heat, duct resistance, diffuser, etc.) See page 29.

External Static Pressure in. w.g.	Air Volume at Specific Blower Taps (cfm)				
	Tap 1	Tap 2	Tap 3	Tap 4	Tap 5
<b>DOWNFLOW</b>	<b>KHB060H4E</b>				
0.0	1351	1405	1801	1982	2339
0.1	1303	1359	1769	1956	2310
0.2	1254	1314	1736	1928	2281
0.3	1206	1268	1703	1900	2253
0.4	1158	1222	1669	1870	2224
0.5	1109	1177	1634	1838	2195
0.6	1061	1131	1598	1806	2166
0.7	1012	1085	1561	1772	2137
0.8	964	1040	1524	1736	2108
0.9	915	994	1486	1700	2080
1.0	867	949	1446	1662	2051
<b>HORIZONTAL</b>	<b>KHB60H4E</b>				
0.0	1329	1353	1728	1886	2206
0.1	1284	1320	1708	1872	2189
0.2	1239	1285	1685	1859	2174
0.3	1193	1258	1661	1832	2157
0.4	1147	1218	1636	1814	2135
0.5	1100	1178	1608	1796	2118
0.6	1052	1125	1579	1770	2102
0.7	1004	1085	1548	1743	2080
0.8	955	1044	1516	1716	2058
0.9	906	991	1481	1689	2036
1.0	856	938	1445	1654	2020

**BLOWER DATA - BELT DRIVE**

**3 TON**

**BLOWER TABLE INCLUDES RESISTANCE FOR BASE UNIT ONLY WITH DRY INDOOR COIL AND AIR FILTERS IN PLACE.**

FOR ALL UNITS ADD:

1 - Any factory installed options air resistance (economizer, wet coil, etc.).

2 - Any field installed accessories air resistance (electric heat, duct resistance, diffuser, etc.).

See page 29 for blower motors and drives and wet coil and options/accessory air resistance data.

**DOWNFLOW**

**KH 036**

Air Volume cfm	External Static - in. w.g.															
	0.10		0.20		0.30		0.40		0.50		0.60		0.70		0.80	
	RPM	BHP	RPM	BHP	RPM	BHP	RPM	BHP	RPM	BHP	RPM	BHP	RPM	BHP	RPM	BHP
700	447	0.09	517	0.12	589	0.15	663	0.17	739	0.19	815	0.20	883	0.23	938	0.25
800	465	0.10	534	0.14	605	0.17	678	0.19	753	0.21	825	0.23	890	0.25	946	0.27
900	486	0.12	554	0.16	623	0.20	695	0.22	767	0.23	836	0.25	897	0.28	953	0.30
1000	508	0.15	576	0.19	643	0.22	713	0.24	783	0.26	848	0.28	907	0.30	961	0.33
1100	533	0.18	599	0.22	665	0.25	733	0.27	800	0.28	863	0.31	919	0.34	971	0.36
1200	560	0.21	625	0.25	689	0.28	755	0.30	820	0.32	879	0.34	932	0.37	983	0.40
1300	591	0.24	654	0.28	716	0.31	779	0.33	841	0.35	897	0.38	948	0.41	996	0.44
1400	631	0.26	690	0.30	748	0.34	807	0.36	864	0.39	916	0.42	964	0.46	1011	0.49
1500	676	0.28	729	0.33	782	0.36	835	0.40	887	0.43	935	0.47	981	0.50	1028	0.54

Air Volume cfm	External Static - in. w.g.															
	0.90		1.00		1.10		1.20		1.30		1.40		1.50		1.60	
	RPM	BHP	RPM	BHP	RPM	BHP	RPM	BHP	RPM	BHP	RPM	BHP	RPM	BHP	RPM	BHP
700	988	0.27	1039	0.29	1088	0.31	---	---	---	---	---	---	---	---	---	---
800	996	0.30	1047	0.32	1098	0.34	1144	0.36	1185	0.39	1224	0.42	---	---	---	---
900	1004	0.33	1055	0.35	1106	0.37	1152	0.40	1193	0.43	1232	0.46	1269	0.49	1305	0.52
1000	1011	0.36	1062	0.38	1111	0.41	1157	0.43	1199	0.47	1238	0.50	1276	0.53	1311	0.56
1100	1020	0.39	1070	0.41	1118	0.44	1163	0.47	1206	0.51	1245	0.54	1282	0.58	1318	0.61
1200	1031	0.43	1079	0.45	1127	0.48	1171	0.52	1213	0.55	1252	0.59	1289	0.62	1324	0.66
1300	1044	0.47	1091	0.49	1137	0.53	1181	0.56	1221	0.60	1259	0.64	1296	0.68	1330	0.71
1400	1058	0.51	1105	0.54	1150	0.57	1191	0.61	1231	0.65	1268	0.69	1303	0.73	1337	0.77
1500	1074	0.56	1120	0.59	1163	0.63	1203	0.67	1241	0.71	1277	0.75	1312	0.79	1345	0.82

**BLOWER DATA - BELT DRIVE****3 TON****BLOWER TABLE INCLUDES RESISTANCE FOR BASE UNIT ONLY WITH DRY INDOOR COIL AND AIR FILTERS IN PLACE.**

FOR ALL UNITS ADD:

1 - Any factory installed options air resistance (economizer, wet coil, etc.).

2 - Any field installed accessories air resistance (electric heat, duct resistance, diffuser, etc.).

See page 29 for blower motors and drives and wet coil and options/accessory air resistance data.

**HORIZONTAL****KH 036**

Air Volume cfm	External Static - in. w.g.															
	0.10		0.20		0.30		0.40		0.50		0.60		0.70		0.80	
	RPM	BHP	RPM	BHP	RPM	BHP	RPM	BHP	RPM	BHP	RPM	BHP	RPM	BHP	RPM	BHP
700	445	0.08	516	0.11	591	0.13	670	0.15	753	0.16	820	0.19	870	0.22	918	0.24
800	463	0.09	534	0.12	608	0.14	685	0.16	766	0.18	830	0.21	878	0.24	926	0.27
900	485	0.11	554	0.14	627	0.16	703	0.18	780	0.21	841	0.23	888	0.27	935	0.30
1000	509	0.13	578	0.16	649	0.19	722	0.21	796	0.23	854	0.26	900	0.29	947	0.33
1100	537	0.16	605	0.19	674	0.21	744	0.24	813	0.26	868	0.29	913	0.33	959	0.36
1200	567	0.19	633	0.22	700	0.24	768	0.27	833	0.30	884	0.33	928	0.37	974	0.40
1300	599	0.22	664	0.25	729	0.28	793	0.30	853	0.33	902	0.37	945	0.41	990	0.44
1400	634	0.26	697	0.29	758	0.31	819	0.34	875	0.38	921	0.42	964	0.46	1008	0.49
1500	669	0.30	730	0.33	789	0.36	846	0.39	897	0.42	941	0.47	983	0.51	1028	0.54
Air Volume cfm	External Static - in. w.g.															
	0.90		1.00		1.10		1.20		1.30		1.40		1.50		1.60	
	RPM	BHP	RPM	BHP	RPM	BHP	RPM	BHP	RPM	BHP	RPM	BHP	RPM	BHP	RPM	BHP
700	969	0.27	1021	0.29	1071	0.32	---	---	---	---	---	---	---	---	---	---
800	977	0.29	1030	0.32	1082	0.34	1128	0.37	1169	0.40	1205	0.42	---	---	---	---
900	986	0.32	1039	0.35	1090	0.37	1137	0.40	1177	0.43	1214	0.46	1248	0.49	1280	0.51
1000	997	0.35	1048	0.38	1098	0.41	114	0.44	1184	0.47	1221	0.50	1255	0.53	1287	0.56
1100	1008	0.39	1059	0.41	1107	0.44	1150	0.47	1191	0.51	1228	0.54	1263	0.57	1295	0.60
1200	1022	0.43	1071	0.45	1117	0.48	1160	0.52	1200	0.55	1237	0.59	1271	0.62	1303	0.66
1300	1037	0.47	1058	0.50	1130	0.53	1171	0.57	1210	0.60	1246	0.64	1280	0.68	1312	0.71
1400	1054	0.52	1100	0.54	1144	0.58	1183	0.62	1221	0.66	1256	0.70	1290	0.73	1321	0.77
1500	1073	0.57	1117	0.60	1159	0.64	1197	0.67	1234	0.71	1268	0.75	1301	0.79	1332	0.83

## BLOWER DATA - BELT DRIVE - KHA048

BLOWER TABLE INCLUDES RESISTANCE FOR BASE UNIT ONLY WITH DRY INDOOR COIL AND AIR FILTERS IN PLACE.

FOR ALL UNITS ADD:

1 - Any factory installed options air resistance (economizer, wet coil, etc.).

2 - Any field installed accessories air resistance (duct resistance, diffuser, etc.).

See page 29 for blower motors and drives and wet coil and options/accessory air resistance data.

### DOWNFLOW

Air Volume cfm	External Static - in. w.g.															
	0.10		0.20		0.30		0.40		0.50		0.60		0.70		0.80	
	RPM	BHP	RPM	BHP	RPM	BHP	RPM	BHP	RPM	BHP	RPM	BHP	RPM	BHP	RPM	BHP
	Field Furnished						Kit A02									
1200	560	0.21	625	0.25	689	0.28	755	0.30	820	0.32	879	0.34	932	0.37	983	0.40
1300	591	0.24	654	0.28	716	0.31	779	0.33	841	0.35	897	0.38	948	0.41	996	0.44
1400	631	0.26	690	0.30	748	0.34	807	0.36	864	0.39	916	0.42	964	0.46	1011	0.49
1500	675	0.28	729	0.33	782	0.36	835	0.40	887	0.43	935	0.47	981	0.50	1028	0.54
1600	718	0.31	766	0.35	814	0.40	862	0.44	910	0.48	955	0.52	1000	0.55	1046	0.59
1700	756	0.34	799	0.39	843	0.44	887	0.49	932	0.53	976	0.57	1020	0.61	1066	0.64
1800	787	0.40	828	0.45	870	0.50	912	0.55	955	0.59	999	0.63	1043	0.67	1089	0.70
1900	815	0.46	855	0.51	897	0.57	939	0.62	981	0.66	1024	0.69	1068	0.73	1113	0.76
2000	843	0.53	884	0.59	925	0.64	968	0.68	1009	0.72	1052	0.76	1095	0.79	1138	0.83

Air Volume cfm	External Static - in. w.g.															
	0.90		1.00		1.10		1.20		1.30		1.40		1.50		1.60	
	RPM	BHP	RPM	BHP	RPM	BHP	RPM	BHP	RPM	BHP	RPM	BHP	RPM	BHP	RPM	BHP
	Kit A02				Kit A06											
1200	1031	0.43	1079	0.45	1127	0.48	1171	0.52	1213	0.55	1252	0.59	1289	0.62	1324	0.66
1300	1044	0.47	1091	0.49	1137	0.53	1181	0.56	1221	0.60	1259	0.64	1296	0.68	1330	0.71
1400	1058	0.51	1105	0.54	1150	0.57	1191	0.61	1231	0.65	1268	0.69	1303	0.73	1337	0.77
1500	1074	0.56	1120	0.59	1163	0.63	1203	0.67	1241	0.71	1277	0.75	1312	0.79	1345	0.82
1600	1092	0.61	1137	0.65	1178	0.68	1216	0.72	1253	0.76	1288	0.80	1321	0.84	1354	0.88
1700	1112	0.67	1155	0.70	1193	0.75	1230	0.79	1265	0.83	1299	0.87	1332	0.91	1364	0.95
1800	1133	0.73	1174	0.77	1209	0.81	1244	0.85	1278	0.90	1311	0.94	1343	0.98	1375	1.02
1900	1156	0.80	1193	0.84	1226	0.89	1260	0.93	1293	0.97	1325	1.01	1356	1.06	1388	1.10
2000	1178	0.87	1213	0.92	1243	0.97	1275	1.02	1307	1.06	1339	1.10	1370	1.14	1402	1.18

### HORIZONTAL

Air Volume cfm	External Static - in. w.g.															
	0.10		0.20		0.30		0.40		0.50		0.60		0.70		0.80	
	RPM	BHP	RPM	BHP	RPM	BHP	RPM	BHP	RPM	BHP	RPM	BHP	RPM	BHP	RPM	BHP
	Field Furnished						Kit A02									
1200	567	0.19	633	0.22	700	0.24	768	0.27	833	0.30	884	0.33	928	0.37	974	0.40
1300	599	0.22	664	0.25	729	0.28	793	0.30	853	0.33	902	0.37	945	0.41	990	0.44
1400	634	0.26	697	0.29	758	0.31	819	0.34	875	0.38	921	0.42	964	0.46	1008	0.49
1500	669	0.30	730	0.33	789	0.36	846	0.39	897	0.42	941	0.47	983	0.51	1028	0.54
1600	705	0.34	763	0.37	819	0.40	873	0.43	921	0.48	963	0.52	1004	0.56	1048	0.59
1700	741	0.38	796	0.41	850	0.45	900	0.49	945	0.53	985	0.58	1026	0.62	1070	0.65
1800	776	0.43	829	0.46	880	0.51	927	0.55	970	0.60	1009	0.64	1050	0.68	1093	0.71
1900	812	0.48	862	0.52	910	0.57	955	0.62	996	0.66	1035	0.71	1076	0.74	1118	0.78
2000	847	0.54	895	0.59	941	0.64	984	0.69	1023	0.74	1062	0.78	1103	0.81	1144	0.85

Air Volume cfm	External Static - in. w.g.															
	0.90		1.00		1.10		1.20		1.30		1.40		1.50		1.60	
	RPM	BHP	RPM	BHP	RPM	BHP	RPM	BHP	RPM	BHP	RPM	BHP	RPM	BHP	RPM	BHP
	Kit A02				Kit A06											
1200	1022	0.43	1071	0.45	1117	0.48	1160	0.52	1200	0.55	1237	0.59	1271	0.62	1303	0.66
1300	1037	0.47	1085	0.50	1130	0.53	1171	0.57	1210	0.60	1246	0.64	1280	0.68	1312	0.71
1400	1054	0.52	1100	0.54	1144	0.58	1183	0.62	1221	0.66	1256	0.70	1290	0.73	1321	0.77
1500	1073	0.57	1117	0.60	1159	0.64	1197	0.67	1234	0.71	1268	0.75	1301	0.79	1332	0.83
1600	1093	0.62	1136	0.66	1175	0.70	1212	0.74	1247	0.78	1281	0.82	1313	0.86	1344	0.90
1700	1114	0.68	1155	0.72	1192	0.76	1227	0.80	1262	0.85	1295	0.89	1327	0.93	1358	0.97
1800	1136	0.75	1175	0.79	1210	0.83	1245	0.88	1278	0.92	1311	0.97	1342	1.01	1373	1.05
1900	1159	0.82	1197	0.86	1229	0.92	1263	0.97	1296	1.01	1328	1.06	1359	1.10	1390	1.14
2000	1183	0.90	1218	0.95	1249	1.01	1282	1.06	1314	1.11	1346	1.15	1377	1.20	1408	1.24

**BLOWER DATA - BELT DRIVE**

**4 TON**

**BLOWER TABLE INCLUDES RESISTANCE FOR BASE UNIT ONLY WITH DRY INDOOR COIL AND AIR FILTERS IN PLACE.**

FOR ALL UNITS ADD:

1 - Any factory installed options air resistance (economizer, wet coil, etc.).

2 - Any field installed accessories air resistance (electric heat, duct resistance, diffuser, etc.).

See page 29 for blower motors and drives and wet coil and options/accessory air resistance data.

**DOWNFLOW**

**KHB048H4T**

Air Volume cfm	External Static - in. w.g.															
	0.10		0.20		0.30		0.40		0.50		0.60		0.70		0.80	
	RPM	BHP	RPM	BHP	RPM	BHP	RPM	BHP	RPM	BHP	RPM	BHP	RPM	BHP	RPM	BHP
900	466	0.10	525	0.14	586	0.17	646	0.20	729	0.20	821	0.19	899	0.20	953	0.23
1000	484	0.12	543	0.16	603	0.19	664	0.22	745	0.23	834	0.23	908	0.24	959	0.26
1100	505	0.15	563	0.18	622	0.22	682	0.25	762	0.26	847	0.26	917	0.27	966	0.30
1200	527	0.18	584	0.21	643	0.25	702	0.28	779	0.30	860	0.30	927	0.31	973	0.34
1300	550	0.21	607	0.25	664	0.29	722	0.32	797	0.33	875	0.34	937	0.35	981	0.38
1400	574	0.25	630	0.29	687	0.32	744	0.35	817	0.37	890	0.38	949	0.39	991	0.42
1500	603	0.28	659	0.32	714	0.36	770	0.39	839	0.41	907	0.42	962	0.44	1002	0.47
1600	651	0.29	703	0.33	754	0.37	806	0.41	867	0.43	927	0.45	976	0.48	1014	0.51
1700	708	0.30	754	0.34	800	0.38	846	0.42	898	0.46	949	0.49	992	0.53	1028	0.57
1800	764	0.31	804	0.36	844	0.40	884	0.45	927	0.49	970	0.54	1008	0.58	1044	0.63
1900	812	0.34	847	0.39	881	0.44	916	0.49	953	0.54	990	0.59	1025	0.64	1061	0.69
2000	857	0.42	889	0.47	920	0.52	952	0.57	986	0.62	1020	0.68	1055	0.73	1091	0.77

Air Volume cfm	External Static - in. w.g.															
	0.90		1.00		1.10		1.20		1.30		1.40		1.50		1.60	
	RPM	BHP	RPM	BHP	RPM	BHP	RPM	BHP	RPM	BHP	RPM	BHP	RPM	BHP	RPM	BHP
900	---	---	---	---	---	---	---	---	---	---	---	---	---	---	---	---
1000	996	0.31	1034	0.35	---	---	---	---	---	---	---	---	---	---	---	---
1100	1001	0.34	1040	0.38	1083	0.42	1128	0.46	1176	0.49	---	---	---	---	---	---
1200	1008	0.38	1047	0.42	1089	0.46	1133	0.49	1180	0.53	1224	0.56	1261	0.60	---	---
1300	1017	0.42	1055	0.46	1097	0.50	1139	0.53	1184	0.57	1228	0.60	1264	0.63	1295	0.67
1400	1026	0.46	1065	0.50	1106	0.54	1147	0.57	1191	0.61	1233	0.64	1269	0.68	1300	0.71
1500	1038	0.51	1076	0.55	1117	0.59	1157	0.62	1199	0.65	1240	0.69	1275	0.72	1305	0.76
1600	1050	0.56	1089	0.60	1129	0.64	1168	0.67	1209	0.71	1249	0.74	1282	0.78	1312	0.82
1700	1065	0.61	1103	0.65	1142	0.69	1181	0.73	1221	0.76	1259	0.80	1292	0.83	1320	0.88
1800	1081	0.67	1118	0.71	1156	0.75	1194	0.79	1234	0.82	1271	0.86	1302	0.90	1330	0.94
1900	1098	0.73	1135	0.77	1172	0.81	1209	0.85	1248	0.88	1284	0.92	1314	0.97	1341	1.01
2000	1128	0.82	1164	0.86	1201	0.89	1239	0.93	1276	0.97	1310	1.01	1336	1.06	1362	1.10

**BLOWER DATA - BELT DRIVE**

**4 TON**

**BLOWER TABLE INCLUDES RESISTANCE FOR BASE UNIT ONLY WITH DRY INDOOR COIL AND AIR FILTERS IN PLACE.**

FOR ALL UNITS ADD:

1 - Any factory installed options air resistance (economizer, wet coil, etc.).

2 - Any field installed accessories air resistance (electric heat, duct resistance, diffuser, etc.).

See page 29 for blower motors and drives and wet coil and options/accessory air resistance data.

**HORIZONTAL**

**KHB048H4T**

Air Volume cfm	External Static - in. w.g.															
	0.10		0.20		0.30		0.40		0.50		0.60		0.70		0.80	
	RPM	BHP	RPM	BHP	RPM	BHP	RPM	BHP	RPM	BHP	RPM	BHP	RPM	BHP	RPM	BHP
900	464	0.10	514	0.13	576	0.15	644	0.17	728	0.18	817	0.19	893	0.21	951	0.24
1000	482	0.12	533	0.15	595	0.17	662	0.19	744	0.21	829	0.22	902	0.24	957	0.27
1100	504	0.14	556	0.17	617	0.20	683	0.22	762	0.24	843	0.25	912	0.28	965	0.31
1200	528	0.17	581	0.20	641	0.23	706	0.25	782	0.27	859	0.29	924	0.31	974	0.34
1300	556	0.21	609	0.24	669	0.26	731	0.29	804	0.31	877	0.33	938	0.35	985	0.38
1400	592	0.24	645	0.27	702	0.30	763	0.32	830	0.35	898	0.37	953	0.39	997	0.43
1500	641	0.26	692	0.29	746	0.33	801	0.36	862	0.38	921	0.41	970	0.44	1011	0.48
1600	696	0.28	743	0.32	792	0.35	842	0.39	894	0.42	945	0.45	988	0.49	1027	0.53
1700	750	0.31	792	0.35	836	0.39	880	0.43	924	0.47	968	0.51	1007	0.55	1043	0.59
1800	799	0.35	837	0.39	875	0.43	913	0.48	952	0.52	990	0.56	1026	0.61	1061	0.65
1900	840	0.40	873	0.45	907	0.49	941	0.54	976	0.58	1011	0.63	1045	0.67	1080	0.72
2000	883	0.48	913	0.53	944	0.57	976	0.62	1009	0.67	1043	0.71	1078	0.76	1112	0.8

Air Volume cfm	External Static - in. w.g.															
	0.90		1.00		1.10		1.20		1.30		1.40		1.50		1.60	
	RPM	BHP	RPM	BHP	RPM	BHP	RPM	BHP	RPM	BHP	RPM	BHP	RPM	BHP	RPM	BHP
900	995	0.28	1034	0.31	1077	0.35	1121	0.38	---	---	---	---	---	---	---	---
1000	999	0.31	1038	0.34	1081	0.38	1124	0.41	1168	0.44	1211	0.47	---	---	---	---
1100	1006	0.34	1044	0.38	1086	0.41	1129	0.44	1171	0.47	1213	0.50	1253	0.53	1293	0.56
1200	1014	0.38	1052	0.42	1093	0.45	1135	0.48	1176	0.51	1217	0.54	1257	0.58	1296	0.61
1300	1023	0.42	1061	0.46	1102	0.50	1143	0.53	1184	0.56	1224	0.59	1263	0.62	1302	0.66
1400	1035	0.47	1073	0.51	1112	0.54	1153	0.57	1193	0.61	1232	0.64	1271	0.67	1309	0.71
1500	1048	0.52	1086	0.56	1125	0.59	1164	0.63	1204	0.66	1243	0.69	1280	0.73	1317	0.77
1600	1063	0.57	1100	0.61	1139	0.65	1178	0.68	1216	0.71	1254	0.75	1291	0.79	1326	0.83
1700	1079	0.63	1116	0.67	1154	0.71	1192	0.74	1230	0.78	1267	0.81	1302	0.85	1337	0.89
1800	1097	0.69	1133	0.73	1171	0.77	1209	0.80	1246	0.84	1281	0.88	1315	0.92	1349	0.96
1900	1116	0.76	1152	0.80	1189	0.84	1226	0.87	1262	0.91	1296	0.95	1329	0.99	1361	1.03
2000	1148	0.84	1183	0.88	1220	0.92	1257	0.96	1291	1.00	1323	1.04	1354	1.08	1385	1.12



**BLOWER DATA - BELT DRIVE**

**5 TON**

**BLOWER TABLE INCLUDES RESISTANCE FOR BASE UNIT ONLY WITH DRY INDOOR COIL AND AIR FILTERS IN PLACE.**

FOR ALL UNITS ADD:

1 - Any factory installed options air resistance (economizer, wet coil, etc.).

2 - Any field installed accessories air resistance (electric heat, duct resistance, diffuser, etc.).

See page 29 for blower motors and drives and wet coil and options/accessory air resistance data.

**DOWNFLOW**

**KH 060**

Air Volume cfm	External Static - in. w.g.															
	0.10		0.20		0.30		0.40		0.50		0.60		0.70		0.80	
	RPM	BHP	RPM	BHP	RPM	BHP	RPM	BHP	RPM	BHP	RPM	BHP	RPM	BHP	RPM	BHP
1100	512	0.15	571	0.19	630	0.23	690	0.26	770	0.26	854	0.26	922	0.27	970	0.30
1200	535	0.18	593	0.22	651	0.26	710	0.30	788	0.30	868	0.30	933	0.31	978	0.34
1300	559	0.22	616	0.26	674	0.29	732	0.34	807	0.34	883	0.34	944	0.35	987	0.38
1400	584	0.26	641	0.29	698	0.33	755	0.37	827	0.37	899	0.38	956	0.40	997	0.43
1500	615	0.29	671	0.33	726	0.36	782	0.41	850	0.41	917	0.42	970	0.44	1009	0.47
1600	665	0.30	716	0.34	768	0.38	819	0.44	879	0.44	937	0.46	985	0.49	1022	0.52
1700	723	0.31	768	0.35	814	0.39	860	0.47	910	0.47	959	0.50	1001	0.54	1037	0.58
1800	779	0.32	818	0.37	857	0.41	897	0.50	939	0.50	980	0.55	1018	0.59	1054	0.64
1900	826	0.36	859	0.41	894	0.45	928	0.56	964	0.56	1000	0.61	1036	0.66	1072	0.70
2000	857	0.42	889	0.47	920	0.52	952	0.62	986	0.62	1020	0.68	1055	0.73	1091	0.77
2100	878	0.49	909	0.54	940	0.59	973	0.70	1006	0.70	1041	0.75	1076	0.80	1112	0.85
2200	897	0.55	929	0.61	961	0.66	994	0.78	1028	0.78	1063	0.83	1099	0.89	1134	0.93
2300	918	0.62	950	0.68	983	0.74	1017	0.86	1052	0.86	1087	0.92	1122	0.97	1157	1.02
2400	941	0.70	974	0.77	1008	0.83	1042	0.96	1077	0.96	1111	1.01	1146	1.06	1181	1.11

Air Volume cfm	External Static - in. w.g.															
	0.90		1.00		1.10		1.20		1.30		1.40		1.50		1.60	
	RPM	BHP	RPM	BHP	RPM	BHP	RPM	BHP	RPM	BHP	RPM	BHP	RPM	BHP	RPM	BHP
1100	1006	0.35	1045	0.39	1089	0.43	1134	0.46	---	---	---	---	---	---	---	---
1200	1013	0.38	1053	0.42	1095	0.46	1139	0.50	1186	0.53	1230	0.57	1266	0.60	---	---
1300	1022	0.42	1062	0.46	1104	0.50	1146	0.54	1192	0.57	1234	0.60	1269	0.64	1301	0.68
1400	1033	0.47	1072	0.51	1114	0.55	1155	0.58	1199	0.61	1240	0.65	1275	0.68	1305	0.72
1500	1045	0.52	1085	0.56	1125	0.60	1165	0.63	1208	0.66	1248	0.69	1281	0.73	1311	0.77
1600	1059	0.57	1098	0.61	1138	0.65	1177	0.68	1218	0.71	1257	0.75	1290	0.79	1319	0.83
1700	1074	0.62	1113	0.66	1152	0.70	1190	0.74	1231	0.77	1268	0.80	1299	0.84	1328	0.89
1800	1091	0.68	1129	0.72	1167	0.76	1205	0.80	1244	0.83	1280	0.87	1310	0.91	1338	0.95
1900	1109	0.75	1146	0.79	1183	0.82	1221	0.86	1260	0.90	1294	0.94	1323	0.98	1349	1.02
2000	1128	0.82	1164	0.86	1201	0.89	1239	0.93	1276	0.97	1310	1.01	1336	1.06	1362	1.10
2100	1148	0.89	1185	0.93	1221	0.97	1258	1.01	1294	1.05	1325	1.09	1351	1.14	1376	1.19
2200	1170	0.97	1206	1.01	1242	1.05	1277	1.09	1311	1.14	1341	1.18	1365	1.23	1390	1.28
2300	1193	1.06	1228	1.09	1262	1.14	1295	1.19	1327	1.24	1355	1.29	1380	1.33	1406	1.37
2400	1216	1.15	1250	1.19	1282	1.24	1313	1.30	1343	1.36	1371	1.40	1396	1.44	1423	1.48

**BLOWER DATA - BELT DRIVE**

**5 TON**

**BLOWER TABLE INCLUDES RESISTANCE FOR BASE UNIT ONLY WITH DRY INDOOR COIL AND AIR FILTERS IN PLACE.**

FOR ALL UNITS ADD:

- 1 - Any factory installed options air resistance (economizer, wet coil, etc.).
  - 2 - Any field installed accessories air resistance (electric heat, duct resistance, diffuser, etc.).
- See page 29 for blower motors and drives and wet coil and options/accessory air resistance data.

**HORIZONTAL**

**KH 060**

Air Volume cfm	External Static - in. w.g.															
	0.10		0.20		0.30		0.40		0.50		0.60		0.70		0.80	
	RPM	BHP	RPM	BHP	RPM	BHP	RPM	BHP	RPM	BHP	RPM	BHP	RPM	BHP	RPM	BHP
1100	509	0.15	562	0.18	624	0.20	691	0.22	771	0.24	852	0.25	919	0.28	970	0.31
1200	535	0.18	589	0.21	650	0.23	715	0.25	792	0.27	869	0.29	932	0.32	980	0.35
1300	564	0.21	618	0.24	678	0.27	741	0.29	815	0.31	887	0.33	946	0.36	991	0.39
1400	604	0.24	657	0.27	715	0.30	775	0.33	842	0.35	908	0.37	962	0.40	1004	0.43
1500	656	0.26	706	0.30	760	0.33	814	0.36	874	0.39	931	0.41	979	0.45	1019	0.48
1600	712	0.29	758	0.32	807	0.36	855	0.39	906	0.43	955	0.46	997	0.50	1035	0.54
1700	766	0.32	808	0.36	850	0.40	892	0.44	936	0.47	978	0.51	1016	0.56	1052	0.60
1800	814	0.36	851	0.40	888	0.44	925	0.49	963	0.53	1000	0.57	1035	0.62	1071	0.66
1900	853	0.41	886	0.46	919	0.50	952	0.55	986	0.60	1021	0.64	1056	0.69	1091	0.73
2000	883	0.48	913	0.53	944	0.57	976	0.62	1009	0.67	1043	0.71	1078	0.76	1112	0.80
2100	906	0.56	936	0.60	967	0.65	999	0.70	1033	0.75	1067	0.79	1101	0.84	1135	0.88
2200	930	0.64	960	0.68	991	0.73	1024	0.78	1058	0.83	1092	0.88	1126	0.92	1160	0.96
2300	954	0.72	985	0.77	1017	0.82	1051	0.87	1085	0.92	1119	0.96	1152	1.00	1186	1.04
2400	981	0.81	1013	0.86	1046	0.91	1079	0.96	1113	1.00	1180	1.05	1180	1.09	1213	1.13

Air Volume cfm	External Static - in. w.g.															
	0.90		1.00		1.10		1.20		1.30		1.40		1.50		1.60	
	RPM	BHP	RPM	BHP	RPM	BHP	RPM	BHP	RPM	BHP	RPM	BHP	RPM	BHP	RPM	BHP
1100	1010	35.00	1049	0.38	1091	0.42	1134	0.45	1176	0.78	1218	0.51	1258	0.54	1297	0.57
1200	1019	0.38	1058	0.42	1099	0.46	1141	0.49	1182	0.52	1223	0.55	1263	0.58	1302	0.61
1300	1030	0.43	1068	0.47	1108	0.50	1149	0.53	1190	0.56	1230	0.59	1270	0.63	1308	0.66
1400	1042	0.47	1080	0.51	1120	0.55	1160	0.58	1200	0.61	1240	0.65	1278	0.68	1315	0.72
1500	1056	0.53	1094	0.57	1133	0.60	1172	0.63	1212	0.67	1250	0.70	1288	0.74	1324	0.77
1600	1071	0.58	1109	0.62	1147	0.66	1186	0.69	1225	0.72	1263	0.76	1299	0.80	1334	0.83
1700	1088	0.64	1126	0.68	1164	0.72	1202	0.75	1240	0.78	1276	0.82	1311	0.86	1345	0.90
1800	1107	0.70	1143	0.74	1181	0.78	1219	0.81	1256	0.85	1290	0.89	1324	0.93	1357	0.97
1900	1126	0.77	1163	0.81	1200	0.85	1237	0.88	1273	0.92	1306	0.96	1339	1.00	1371	1.04
2000	1148	0.84	1183	0.88	1220	0.92	1257	0.96	1291	1.00	1323	1.04	1354	1.08	1385	1.12
2100	1170	0.92	1206	0.96	1242	1.00	1277	1.04	1310	1.08	1340	1.13	1370	1.17	1401	1.21
2200	1195	1.00	1230	1.04	1265	1.08	1299	1.13	1330	1.18	1359	1.23	1388	1.27	1418	1.31
2300	1220	1.08	1254	1.13	1288	1.17	1320	1.23	1350	1.28	1378	1.34	1406	1.38	1435	1.42
2400	1245	1.18	1278	1.22	1311	1.28	1341	1.33	1370	1.40	1397	1.45	1425	1.50	1454	1.54

## BLOWER DATA - BELT DRIVE - DOWNFLOW - KHA072, KHB074

BLOWER TABLE INCLUDES RESISTANCE FOR BASE UNIT ONLY WITH DRY INDOOR COIL AND AIR FILTERS IN PLACE.

FOR ALL UNITS ADD:

1 - Any factory installed options air resistance (economizer, wet coil, etc.).

2 - Any field installed accessories air resistance (duct resistance, diffuser, etc.).

See page 29 for blower motors and drives and wet coil and options/accessory air resistance data.

Air Volume cfm	External Static - in. w.g.															
	0.10		0.20		0.30		0.40		0.50		0.60		0.70		0.80	
	RPM	BHP	RPM	BHP	RPM	BHP	RPM	BHP	RPM	BHP	RPM	BHP	RPM	BHP	RPM	BHP
	Field Furnished										Kit A04					
1900	826	0.36	859	0.41	894	0.45	928	0.50	964	0.56	1000	0.61	1036	0.66	1072	0.70
2000	857	0.42	889	0.47	920	0.52	952	0.57	986	0.62	1020	0.68	1055	0.73	1091	0.77
2100	878	0.49	909	0.54	940	0.59	973	0.64	1006	0.70	1041	0.75	1076	0.80	1112	0.85
2200	897	0.55	929	0.61	961	0.66	994	0.72	1028	0.78	1063	0.83	1099	0.89	1134	0.93
2300	918	0.62	950	0.68	983	0.74	1017	0.80	1052	0.86	1087	0.92	1122	0.97	1157	1.02
2400	941	0.70	974	0.77	1008	0.83	1042	0.90	1077	0.96	1111	1.01	1146	1.06	1181	1.11
2500	966	0.79	1000	0.86	1034	0.93	1068	1.00	1103	1.06	1137	1.11	1171	1.16	1205	1.20
2600	994	0.90	1028	0.97	1062	1.04	1096	1.10	1130	1.16	1164	1.21	1197	1.26	1231	1.30
2700	1023	1.01	1057	1.08	1091	1.15	1125	1.22	1159	1.27	1192	1.32	1225	1.37	1258	1.41
2800	1053	1.13	1088	1.21	1122	1.27	1155	1.33	1188	1.39	1221	1.43	1253	1.48	1286	1.53
2900	1085	1.26	1119	1.33	1153	1.40	1186	1.45	1218	1.51	1250	1.55	1281	1.61	1313	1.66

Air Volume cfm	External Static - in. w.g.															
	0.90		1.00		1.10		1.20		1.30		1.40		1.50		1.60	
	RPM	BHP	RPM	BHP	RPM	BHP	RPM	BHP	RPM	BHP	RPM	BHP	RPM	BHP	RPM	BHP
	Kit A04										Kit A08					
1900	1109	0.75	1146	0.79	1183	0.82	1221	0.86	1260	0.90	1294	0.94	1323	0.98	1349	1.02
2000	1128	0.82	1164	0.86	1201	0.89	1239	0.93	1276	0.97	1310	1.01	1336	1.06	1362	1.10
2100	1148	0.89	1185	0.93	1221	0.97	1258	1.01	1294	1.05	1325	1.09	1351	1.14	1376	1.19
2200	1170	0.97	1206	1.01	1242	1.05	1277	1.09	1311	1.14	1341	1.18	1365	1.23	1390	1.28
2300	1193	1.06	1228	1.09	1262	1.14	1295	1.19	1327	1.24	1355	1.29	1380	1.33	1406	1.37
2400	1216	1.15	1250	1.19	1282	1.24	1313	1.30	1343	1.36	1371	1.40	1396	1.44	1423	1.48
2500	1240	1.24	1273	1.29	1302	1.36	1331	1.42	1360	1.48	1388	1.52	1414	1.55	1441	1.58
2600	1265	1.34	1296	1.40	1324	1.47	1352	1.54	1381	1.60	1408	1.64	1434	1.67	1460	1.70
2700	1291	1.46	1321	1.52	1347	1.60	1374	1.67	1403	1.72	1429	1.76	1455	1.79	1481	1.82
2800	1317	1.58	1346	1.66	1372	1.74	1399	1.80	1426	1.85	1451	1.89	1477	1.92	1503	1.95
2900	1343	1.72	1371	1.80	1397	1.88	1424	1.95	1450	1.99	1475	2.02	1500	2.05	1526	2.08

## BLOWER DATA - BELT DRIVE - HORIZONTAL - KHA072, KHB074

**BLOWER TABLE INCLUDES RESISTANCE FOR BASE UNIT ONLY WITH DRY INDOOR COIL AND AIR FILTERS IN PLACE.**

FOR ALL UNITS ADD:

1 - Any factory installed options air resistance (economizer, wet coil, etc.).

2 - Any field installed accessories air resistance (duct resistance, diffuser, etc.).

See page 29 for blower motors and drives and wet coil and options/accessory air resistance data.

Air Volume cfm	External Static - in. w.g.															
	0.10		0.20		0.30		0.40		0.50		0.60		0.70		0.80	
	RPM	BHP	RPM	BHP	RPM	BHP	RPM	BHP	RPM	BHP	RPM	BHP	RPM	BHP	RPM	BHP
	Field Furnished								Kit A04							
1900	853	0.41	886	0.46	919	0.50	952	0.55	986	0.60	1021	0.64	1056	0.69	1091	0.73
2000	883	0.48	913	0.53	944	0.57	976	0.62	1009	0.67	1043	0.71	1078	0.76	1112	0.80
2100	906	0.56	936	0.60	967	0.65	999	0.70	1033	0.75	1067	0.79	1101	0.84	1135	0.88
2200	930	0.64	960	0.68	991	0.73	1024	0.78	1058	0.83	1092	0.88	1126	0.92	1160	0.96
2300	954	0.72	985	0.77	1017	0.82	1051	0.87	1085	0.92	1119	0.96	1152	1.00	1186	1.04
2400	981	0.81	1013	0.86	1046	0.91	1079	0.96	1113	1.00	1146	1.05	1180	1.09	1213	1.13
2500	1010	0.91	1042	0.96	1075	1.00	1109	1.05	1142	1.09	1175	1.14	1207	1.18	1239	1.23
2600	1040	1.01	1073	1.05	1106	1.10	1139	1.14	1171	1.19	1203	1.23	1235	1.28	1266	1.33
2700	1072	1.10	1104	1.15	1137	1.20	1169	1.24	1201	1.29	1232	1.34	1263	1.40	1293	1.46
2800	1105	1.21	1137	1.25	1168	1.30	1200	1.35	1231	1.40	1261	1.46	1291	1.52	1321	1.59
2900	1138	1.32	1169	1.37	1200	1.42	1231	1.47	1261	1.53	1291	1.60	1321	1.66	1350	1.73

Air Volume cfm	External Static - in. w.g.															
	0.90		1.00		1.10		1.20		1.30		1.40		1.50		1.60	
	RPM	BHP	RPM	BHP	RPM	BHP	RPM	BHP	RPM	BHP	RPM	BHP	RPM	BHP	RPM	BHP
	Kit A04														Kit A08	
1900	1126	0.77	1163	0.81	1200	0.85	1237	0.88	1273	0.92	1306	0.96	1339	1.00	1371	1.04
2000	1148	0.84	1183	0.88	1220	0.92	1257	0.96	1291	1.00	1323	1.04	1354	1.08	1385	1.12
2100	1170	0.92	1206	0.96	1242	1.00	1277	1.04	1310	1.08	1340	1.13	1371	1.17	1401	1.21
2200	1195	1.00	1230	1.04	1265	1.08	1299	1.13	1330	1.18	1359	1.23	1388	1.27	1418	1.31
2300	1220	1.08	1254	1.13	1288	1.17	1320	1.23	1350	1.28	1378	1.34	1406	1.38	1435	1.42
2400	1245	1.18	1278	1.22	1311	1.28	1341	1.33	1370	1.40	1397	1.45	1425	1.50	1454	1.54
2500	1271	1.28	1303	1.33	1334	1.39	1363	1.45	1391	1.52	1418	1.57	1446	1.62	1474	1.66
2600	1297	1.39	1328	1.45	1357	1.52	1385	1.58	1412	1.64	1439	1.70	1467	1.74	1495	1.78
2700	1323	1.52	1353	1.58	1382	1.65	1409	1.72	1435	1.77	1462	1.82	1490	1.86	1517	1.90
2800	1351	1.65	1380	1.72	1407	1.78	1434	1.85	1460	1.90	1486	1.95	1513	1.99	1541	2.02
2900	1379	1.79	1407	1.86	1434	1.92	1460	1.98	1485	2.04	1511	2.08	1538	2.12	1565	2.15

## BLOWER DATA

### BELT DRIVE KIT SPECIFICATIONS - STANDARD EFFICIENCY - 036-074

Model No.	Motor HP		No. of Speeds	Drive Kits and RPM Range							
	Nominal	Maximum		A01	A02	A03	A04	A05	A06	A07	A08
036	0.75	0.86	1	673-1010	---	---	---	897-1346	---	---	---
	1	1.15	1	673-1010	---	---	---	897-1346	---	---	---
	1.5	1.7	1	673-1010	---	---	---	897-1346	---	---	---
	2	2.3	1	673-1010	---	---	---	897-1346	---	---	---
048	0.75	0.86	1	---	745-1117	---	---	---	1071-1429	---	---
	1	1.15	1	---	745-1117	---	---	---	1071-1429	---	---
	1.5	1.7	1	---	745-1117	---	---	---	1071-1429	---	---
	2	2.3	1	---	745-1117	---	---	---	1071-1429	---	---
060	0.75	0.86	1	---	---	833-1250	---	---	---	1212-1548	---
	1	1.15	1	---	---	833-1250	---	---	---	1212-1548	---
	1.5	1.7	1	---	---	833-1250	---	---	---	1212-1548	---
	2	2.3	1	---	---	833-1250	---	---	---	1212-1548	---
074	1	1.5	2	---	---	---	968-1340	---	---	---	1193-1591
	2	2.3	2	---	---	---	968-1340	---	---	---	1193-1591

NOTE - Using total air volume and system static pressure requirements determine from blower performance tables rpm and motor hp required. Maximum usable hp of motors furnished are shown. In Canada, nominal motor hp is also maximum usable motor hp. If motors of comparable hp are used, be sure to keep within the service factor limitations outlined on the motor nameplate.

### BELT DRIVE KIT SPECIFICATIONS - HIGH EFFICIENCY - 036-060

Model No.	Motor HP		No. of Speeds	Drive Kits and RPM Range						
	Nominal	Maximum		A01	A02	A03	A05	A06	A07	
036	0.75	0.86	2	low 449-673 high 673-1010	---	---	---	---	---	
	1	1.15	2	---	---	---	low 598-897 high 897-1346	---	---	
048	0.75	0.86	2	---	low 497-673 high 745-1117	---	---	---	---	
	2	2.3	2	---	---	---	---	low 714-953 high 1071-1429	---	
060	1	1.15	2	---	---	low 555-833 high 833-1250	---	---	---	
	2	2.3	2	---	---	---	---	---	low 808-1032 high 1212-1548	

NOTE - Using total air volume and system static pressure requirements determine from blower performance tables rpm and motor hp required. Maximum usable hp of motors furnished are shown. In Canada, nominal motor hp is also maximum usable motor hp. If motors of comparable hp are used, be sure to keep within the service factor limitations outlined on the motor nameplate.

### OPTIONS / ACCESSORIES AIR RESISTANCE - in. w.g.

Air Volume cfm	Wet Indoor Coil		Economizer	Electric Heat	Filters	
	024, 030, 036, 048	060, 074			MERV 8	MERV 13
800	0.01	0.01	0.04	0.01	0.04	0.05
1000	0.02	0.01	0.04	0.03	0.04	0.07
1200	0.02	0.01	0.04	0.06	0.04	0.07
1400	0.03	0.02	0.04	0.09	0.04	0.07
1600	0.04	0.03	0.04	0.12	0.04	0.07
1800	0.05	0.04	0.05	0.15	0.05	0.07
2000	0.06	0.05	0.05	0.18	0.05	0.08
2200	0.08	0.06	0.05	0.20	0.05	0.08
2400	0.09	0.07	0.05	0.22	0.05	0.08
2600	0.10	0.08	0.06	0.24	0.05	0.08
2800	0.11	0.09	0.06	0.26	0.05	0.08
3000	0.13	0.10	0.06	0.28	0.05	0.08

**TABLE 4  
DRIVE COMPONENT MANUFACTURER'S NUMBERS**

Drive No.	DRIVE COMPONENTS					
	MOTOR PULLEY		BLOWER PULLEY		BELTS	
	Browning No.	OEM Part No.	Browning No.	OEM Part No.	Browning No.	OEM Part No.
A01	1VP34 X 7/8	31K6901	AK54 X 1	100244-19	A40	100245-17
A02	1VP34 X 7/8	31K6901	AK49 X 1	100244-18	A39	100245-16
A03	1VP34 X 7/8	31K6901	AK44X 1	100244-16	A39	100245-16
A04	1VP40 X 7/8	79J0301	AK49 X 1	100244-18	A41	100245-18
A05	1VP34 X 7/8	31K6901	AK41 X 1	100244-15	A39	100245-16
A06	1VP44 X 7/8	P-8-1488	AK51 X 1	18L2201	A41	100245-18
A07	1VP50 X 7/8	P-8-2187	AK54 X 1	100244-19	AX43	73K8201
A08	1VP44 X 7/8	P-8-1488	AK46 X 1	100244-17	A40	100245-17

**Start-Up**

**▲ IMPORTANT**

**If unit is equipped with a crankcase heater. Make sure heater is energized 24 hours before unit start-up to prevent compressor damage as a result of slugging.**

**A-Start-Up**

**Heating**

- 1- Set thermostat or temperature control device to initiate a first-stage heating demand.
- 2- A first-stage heating demand (W1) will energize compressors 1 and the outdoor fan.

*Note - L1 reversing valve is de-energized in the heating mode.*

*KH Units With Optional Electric Heat -*

An increased heating demand (W2) will energize electric heat. Electric heat is also energized during the defrost cycle (W1) to maintain discharge air temperature.

**Cooling**

- 1- Initiate first and second stage cooling demands according to instructions provided with thermostat. See table 5 for operation.

*Note - KHB024H, 036H, 048H, 060H & 074S units are equipped with two-stage compressors.*

**TABLE 5  
COOLING OPERATION**

T'Stat Demand	Energized	
<b>024-072S No Economizer or Outdoor Air Unsuitable</b>		
Y1	Compressor	OD Fan
Y2	Compressor	OD Fan
<b>024-072S Unit Equipped With An Economizer</b>		
Y1	Economizer	na
Y2	Economizer + Compressor	OD Fan
<b>074S, 024-060H No Economizer or Outdoor Air Unsuitable</b>		
Y1	Compressor Low Speed <sup>1</sup>	OD Fan Low Sp. <sup>3</sup>
Y2	Compressor High Speed <sup>2</sup>	OD Fan High Sp. <sup>3</sup>
<b>074S, 024-060H Unit Equipped With An Economizer</b>		
Y1	Economizer	na
Y2	Economizer + Compressor Low Speed <sup>1</sup>	OD Fan Low Sp. <sup>3</sup>

<sup>1</sup>67% of full capacity

<sup>2</sup>100% of full capacity

<sup>3</sup>074S outdoor fans are single-speed

*Note - The reversing valve is energized at the same time as the compressor.*

- 2- Units contain one refrigerant circuit or stage.
- 3- Unit is charged with R-410A refrigerant. See unit rating plate for correct amount of charge.
- 4- Refer to Refrigerant Charge and Check section for proper method to check refrigerant charge.

### B-Three Phase Scroll Compressor Voltage Phasing

Three phase scroll compressors must be phased sequentially to ensure correct compressor and blower rotation and operation. Compressor and blower are wired in phase at the factory. Power wires are color-coded as follows: line 1-red, line 2-yellow, line 3-blue.

- 1- Observe suction and discharge pressures and blower rotation on unit start-up.
- 2- Suction pressure must drop, discharge pressure must rise, and blower rotation must match rotation marking.

If pressure differential is not observed or blower rotation is not correct:

- 3- Disconnect all remote electrical power supplies.
- 4- Reverse any two field-installed wires connected to the line side of K1 contactor. Do not reverse wires at blower contactor.

Make sure the connections are tight.

Discharge and suction pressures should operate at their normal start-up ranges.

### C - Refrigerant Charge and Check - KHA036-072S & KHB074S

**WARNING-Do not exceed nameplate charge under any condition.**

This unit is factory charged and should require no further adjustment. If the system requires charge, **reclaim the charge, evacuate the system, and add required nameplate charge.**

*NOTE - System charging is not recommended below 60°F (15°C). In temperatures below 60°F (15°C) , the charge **must** be weighed into the system.*

If weighing facilities are not available, or to check the charge, use the following procedure:

- 1- Attach gauge manifolds and operate unit in cooling mode until system stabilizes (approximately five minutes).
- 2- Check each system separately with all stages operating.
- 3- Use a thermometer to accurately measure the outdoor ambient temperature.
- 4- Apply the outdoor temperature to tables 6 through 10 to determine normal operating pressures.
- 5- Compare the normal operating pressures to the pressures obtained from the gauges. Minor variations in these pressures may be expected due to differences in installations. Significant differences could mean that the system is not properly charged or that a problem exists with some component in the system. **Correct any system problems before proceeding.**

**TABLE 6  
KHA036S NORMAL OPERATING PRESSURES**

Outdoor Coil Entering Air Temp	Dis. ± 10 psig	Suct. ±5 psig
65°F	247	140
75°F	289	143
85°F	331	145
95°F	381	148
105°F	434	151
115°F	492	154

**TABLE 7  
KHA048S NORMAL OPERATING PRESSURES**

Outdoor Coil Entering Air Temp	Dis. ± 10 psig	Suct. ±5 psig
65°F	272	139
75°F	313	142
85°F	359	145
95°F	410	148
105°F	465	150
115°F	529	152

**TABLE 8  
KHA060S NORMAL OPERATING PRESSURES**

Outdoor Coil Entering Air Temp	Dis. ± 10 psig	Suct. ±5 psig
65°F	265	136
75°F	304	139
85°F	348	141
95°F	397	144
105°F	447	147
115°F	507	149

**TABLE 9  
KHA072S NORMAL OPERATING PRESSURES**

Outdoor Coil Entering Air Temp	Dis. ± 10 psig	Suct. ±5 psig
65°F	257	134
75°F	297	138
85°F	340	142
95°F	387	146
105°F	438	149
115°F	493	153

**TABLE 10  
KHB074S NORMAL OPERATING PRESSURES**

Outdoor Coil Entering Air Temp	Dis. ± 10 psig	Suct. ±5 psig
65°F	257	127
75°F	297	134
85°F	340	139
95°F	386	142
105°F	438	146
115°F	491	149

6- If discharge pressure is high, remove refrigerant from the system. If discharge pressure is low, add refrigerant to the system.

- Add or remove charge in increments.
- Allow the system to stabilize each time refrigerant is added or removed.

7- Use the following approach method along with the normal operating pressures to confirm readings.

**D - Charge Verification - Approach Method - KHA036-072S & KHB074S**

1- Using the same thermometer, compare liquid temperature to outdoor ambient temperature.

Approach Temperature = Liquid temperature minus ambient temperature.

2- Approach temperature should match values in table 11. An approach temperature greater than value shown indicates an undercharge. An approach temperature less than value shown indicates an overcharge.

3- Do not use the approach method if system pressures do not match pressures in tables 6 through 10. The approach method is not valid for grossly over or undercharged systems.

**TABLE 11  
APPROACH TEMPERATURE**

Unit	Liquid Temp. Minus Ambient Temp.
KHA036S	9°F ± 1 (5.0°C ± 0.5)
KHA048S, 060S	11°F ± 1 (6.1°C ± 0.5)
KHA072S, KHB074S	8°F ± 1 (4.4°C ± 0.5)

**E-Refrigerant Charge and Check - KHB024S-060S  
WARNING-Do not exceed nameplate charge under any condition.**

This unit is factory charged and should require no further adjustment. If the system requires additional refrigerant, reclaim the charge, evacuate the system, and add required nameplate charge.

*NOTE - System charging is not recommended below 60°F (15°C). In temperatures below 60°F (15°C), the charge **must** be weighed into the system.*

If weighing facilities are not available, or to check the charge, use the following procedure:

**IMPORTANT - Charge unit in standard cooling mode.**

1- Make sure outdoor coil is clean. Attach gauge manifolds and operate unit at full CFM in cooling mode with economizer disabled until system stabilizes (approximately five minutes). Make sure all outdoor air dampers are closed.

2- Compare the normal operating pressures (see table 12 through 19) to the pressures obtained from the gauges. Check unit components if there are significant differences.

3- Measure the outdoor ambient temperature and the suction pressure. Refer to the appropriate circuit charging curve to determine a target liquid temperature.

*Note - Pressures are listed for sea level applications.*

4- Use the same thermometer to accurately measure the liquid temperature (in the outdoor section).

- If measured liquid temperature is higher than the target liquid temperature, add refrigerant to the system.
- If measured liquid temperature is lower than the target liquid temperature, recover some refrigerant from the system.

5- Add or remove charge in increments. Allow the system to stabilize each time refrigerant is added or removed.

6- Continue the process until measured liquid temperature agrees with the target liquid temperature. Do not go below the target liquid temperature when adjusting charge. Note that suction pressure can change as charge is adjusted.

7- Example KHB024: At 95°F outdoor ambient and a measured suction pressure of 130psig, the target liquid temperature is 101°F. For a measured liquid temperature of 112°F, add charge in increments until measured liquid temperature agrees with the target liquid temperature.



**TABLE 12**

<b>KHB024S Normal Operating Pressures</b>											
Outdoor Coil Entering Air Temperature											
65 °F		75 °F		85 °F		95 °F		105 °F		115 °F	
Suct (psig)	Disc (psig)	Suct (psig)	Disc (psig)	Suct (psig)	Disc (psig)	Suct (psig)	Disc (psig)	Suct (psig)	Disc (psig)	Suct (psig)	Disc (psig)
117	220	119	255	121	297	122	343	123	394	125	449
125	221	127	256	129	297	131	343	132	394	135	451
138	226	145	261	148	302	151	352	155	401	156	459
153	231	164	268	171	311	174	357	177	409	180	465

**TABLE 13**

<b>KHB024H Normal Operating Pressures</b>											
Outdoor Coil Entering Air Temperature											
65 °F		75 °F		85 °F		95 °F		105 °F		115 °F	
Suct (psig)	Disc (psig)	Suct (psig)	Disc (psig)	Suct (psig)	Disc (psig)	Suct (psig)	Disc (psig)	Suct (psig)	Disc (psig)	Suct (psig)	Disc (psig)
113	217	114	254	117	295	119	342	121	395	124	455
120	222	125	259	123	304	128	349	130	401	133	459
141	226	143	262	142	303	145	353	148	404	154	465
154	233	162	270	167	312	170	358	171	410	175	466

**TABLE 14**

<b>KHB030S Normal Operating Pressures</b>											
Outdoor Coil Entering Air Temperature											
65 °F		75 °F		85 °F		95 °F		105 °F		115 °F	
Suct (psig)	Disc (psig)	Suct (psig)	Disc (psig)	Suct (psig)	Disc (psig)	Suct (psig)	Disc (psig)	Suct (psig)	Disc (psig)	Suct (psig)	Disc (psig)
116	227	118	262	120	303	123	347	125	395	127	449
125	229	127	267	129	308	132	349	133	398	136	452
139	235	143	271	146	313	150	360	153	409	155	463
147	239	153	277	159	321	164	366	168	416	174	472

**TABLE 15**

<b>KHB036S Normal Operating Pressures</b>											
Outdoor Coil Entering Air Temperature											
65 °F		75 °F		85 °F		95 °F		105 °F		115 °F	
Suct (psig)	Disc (psig)	Suct (psig)	Disc (psig)	Suct (psig)	Disc (psig)	Suct (psig)	Disc (psig)	Suct (psig)	Disc (psig)	Suct (psig)	Disc (psig)
110	234	110	272	118	317	122	366	125	422	124	475
123	238	122	277	126	320	129	367	131	419	134	478
142	248	144	286	146	329	150	378	150	429	155	491
154	253	163	295	168	336	171	393	173	439	177	500

**TABLE 16**

<b>KHB036H Normal Operating Pressures</b>											
Outdoor Coil Entering Air Temperature											
65 °F		75 °F		85 °F		95 °F		105 °F		115 °F	
Suct (psig)	Disc (psig)	Suct (psig)	Disc (psig)	Suct (psig)	Disc (psig)	Suct (psig)	Disc (psig)	Suct (psig)	Disc (psig)	Suct (psig)	Disc (psig)
113	230	115	268	117	310	119	358	121	412	121	471
121	233	123	273	125	314	128	364	130	417	130	476
142	240	142	278	144	321	146	370	149	425	151	483
157	247	163	286	165	330	168	378	170	431	173	491

**TABLE 17**

<b>KHB048S Normal Operating Pressures</b>											
Outdoor Coil Entering Air Temperature											
65 °F		75 °F		85 °F		95 °F		105 °F		115 °F	
Suct (psig)	Disc (psig)	Suct (psig)	Disc (psig)	Suct (psig)	Disc (psig)	Suct (psig)	Disc (psig)	Suct (psig)	Disc (psig)	Suct (psig)	Disc (psig)
112	239	113	277	115	319	117	363	120	411	120	464
119	244	121	282	123	323	126	368	128	416	130	471
140	253	141	291	142	333	144	377	147	426	149	481
158	264	162	301	165	343	167	389	169	439	170	493

**TABLE 18**

<b>KHB048H Normal Operating Pressures</b>											
Outdoor Coil Entering Air Temperature											
65 °F		75 °F		85 °F		95 °F		105 °F		115 °F	
Suct (psig)	Disc (psig)	Suct (psig)	Disc (psig)	Suct (psig)	Disc (psig)	Suct (psig)	Disc (psig)	Suct (psig)	Disc (psig)	Suct (psig)	Disc (psig)
107	234	109	272	110	314	112	363	116	409	117	462
115	242	117	279	119	321	121	366	123	415	123	470
129	247	134	284	137	328	140	375	143	425	144	480
134	251	145	292	154	335	159	382	162	432	164	489

**TABLE 19**

<b>KHB060S Normal Operating Pressures</b>											
Outdoor Coil Entering Air Temperature											
65 °F		75 °F		85 °F		95 °F		105 °F		115 °F	
Suct (psig)	Disc (psig)	Suct (psig)	Disc (psig)	Suct (psig)	Disc (psig)	Suct (psig)	Disc (psig)	Suct (psig)	Disc (psig)	Suct (psig)	Disc (psig)
115	246	116	284	118	326	120	372	122	423	124	478
123	250	125	288	127	331	129	377	130	428	133	484
139	259	143	299	146	342	147	388	149	440	153	495
149	266	159	308	163	352	167	400	170	452	173	509

**TABLE 20**

<b>KHB060H Normal Operating Pressures</b>											
Outdoor Coil Entering Air Temperature											
65 °F		75 °F		85 °F		95 °F		105 °F		115 °F	
Suct (psig)	Disc (psig)	Suct (psig)	Disc (psig)	Suct (psig)	Disc (psig)	Suct (psig)	Disc (psig)	Suct (psig)	Disc (psig)	Suct (psig)	Disc (psig)
105	236	106	274	109	317	112	365	115	419	119	474
115	243	119	280	119	324	122	372	124	422	129	480
135	251	137	289	139	332	142	381	146	432	148	489
152	261	157	300	160	344	163	392	166	443	170	500

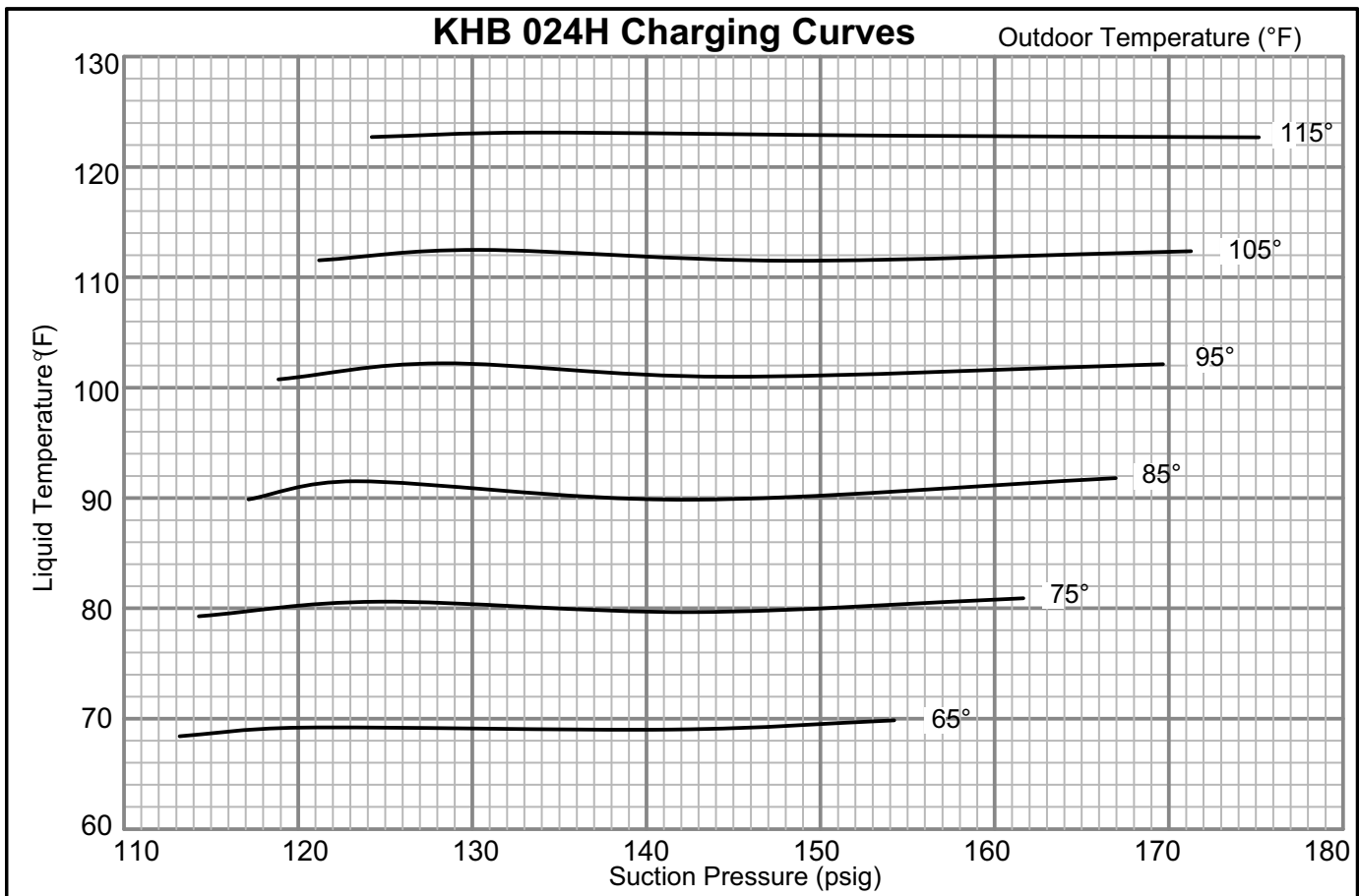
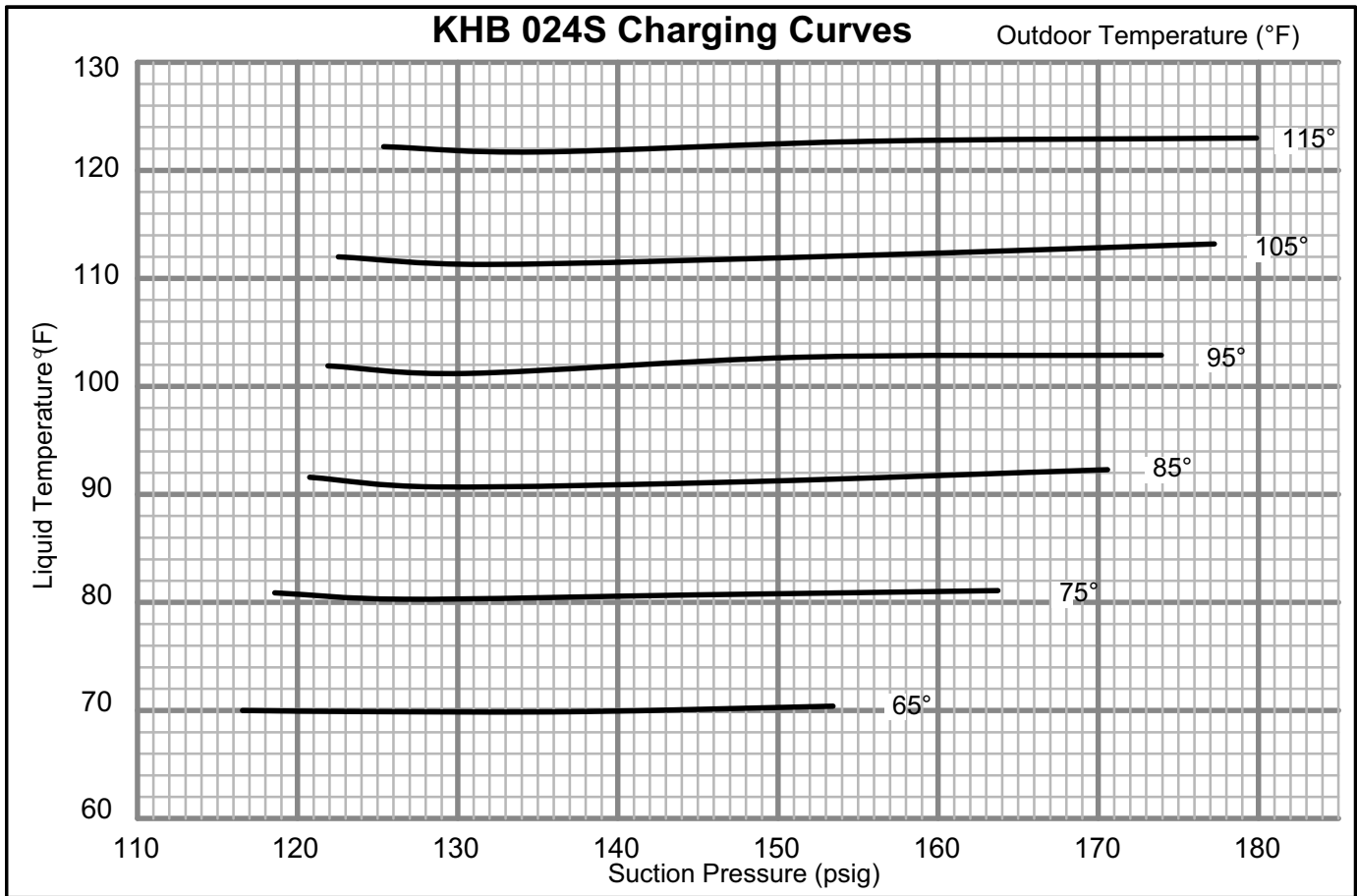

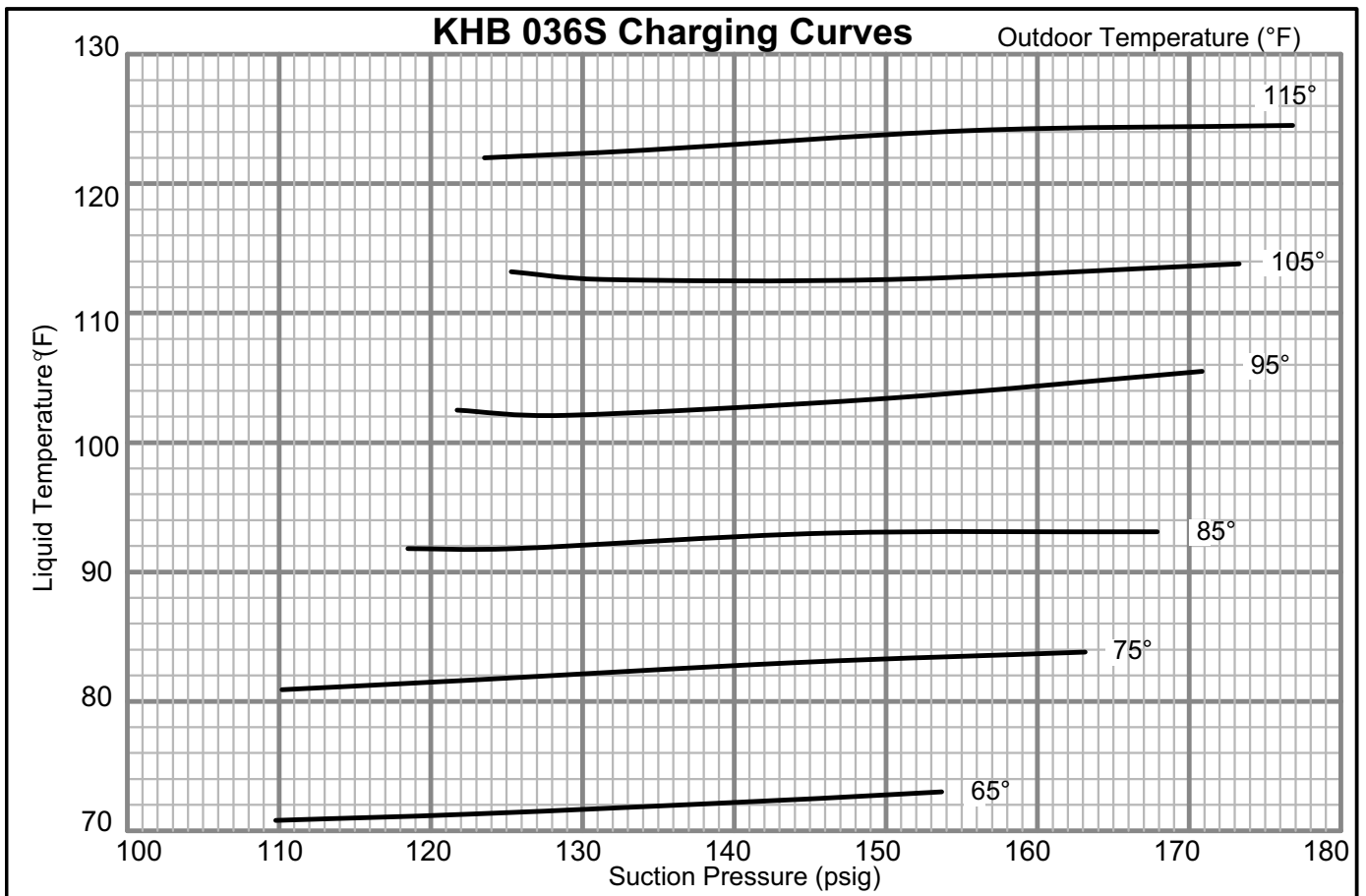
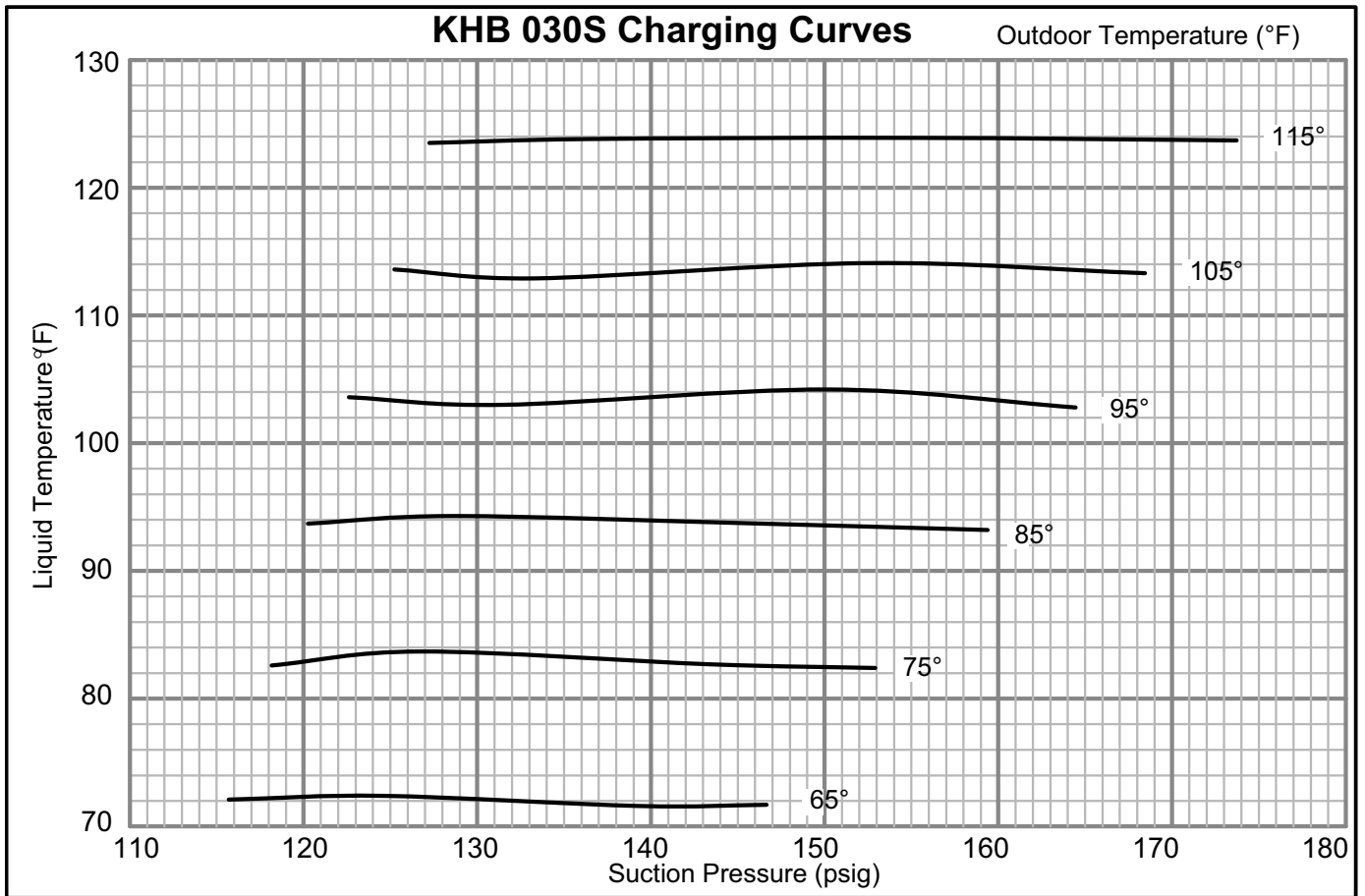

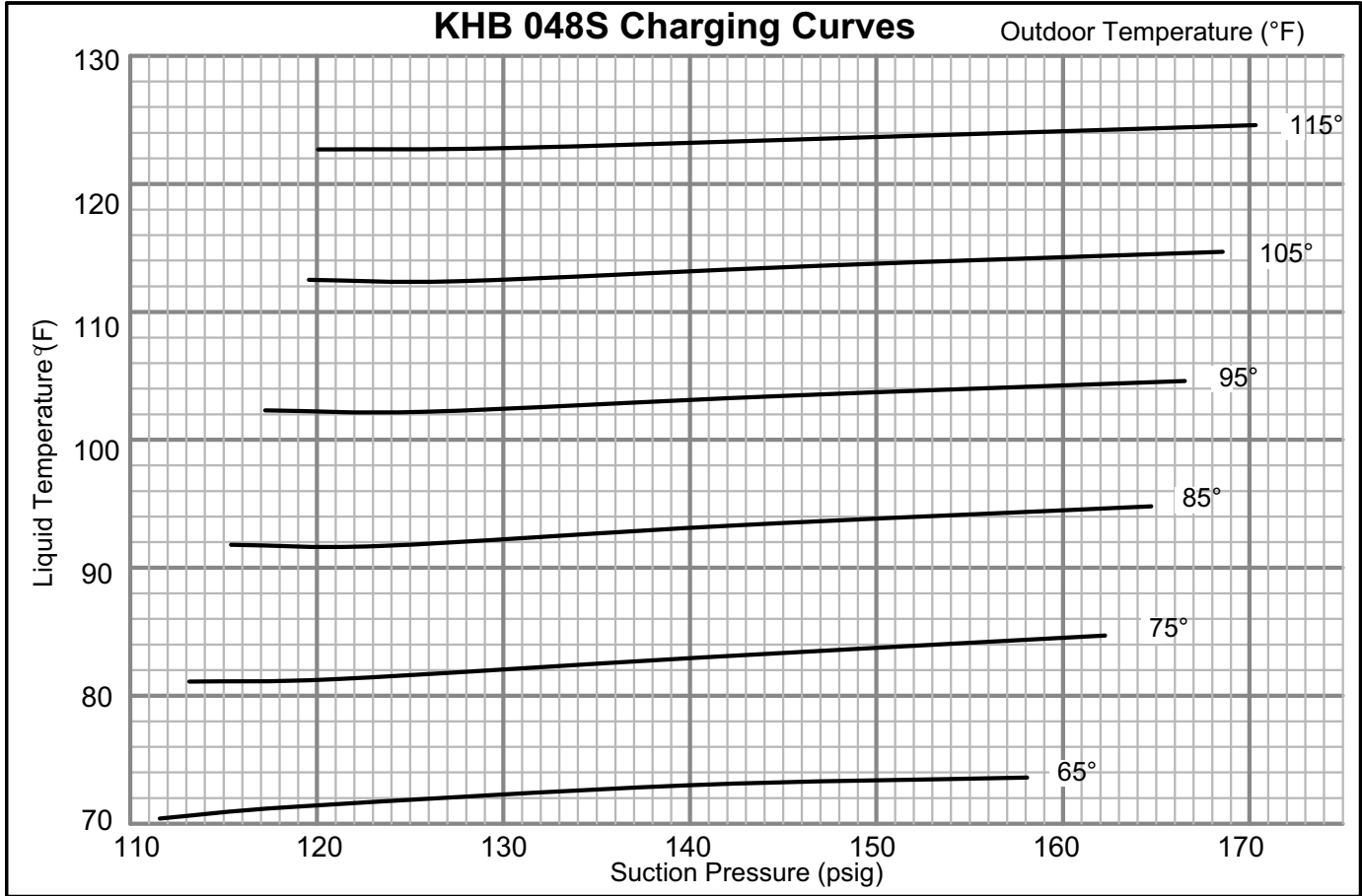
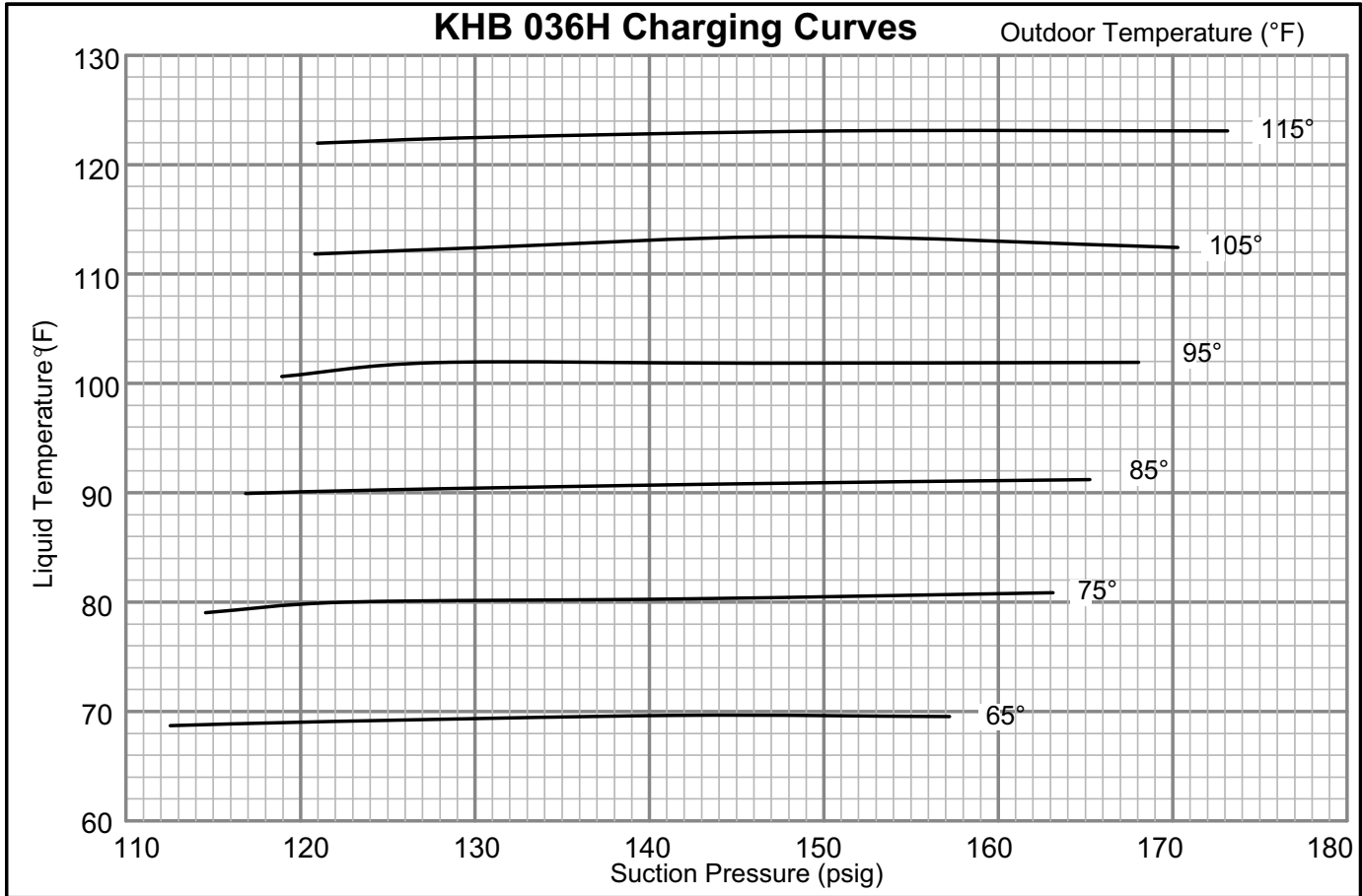

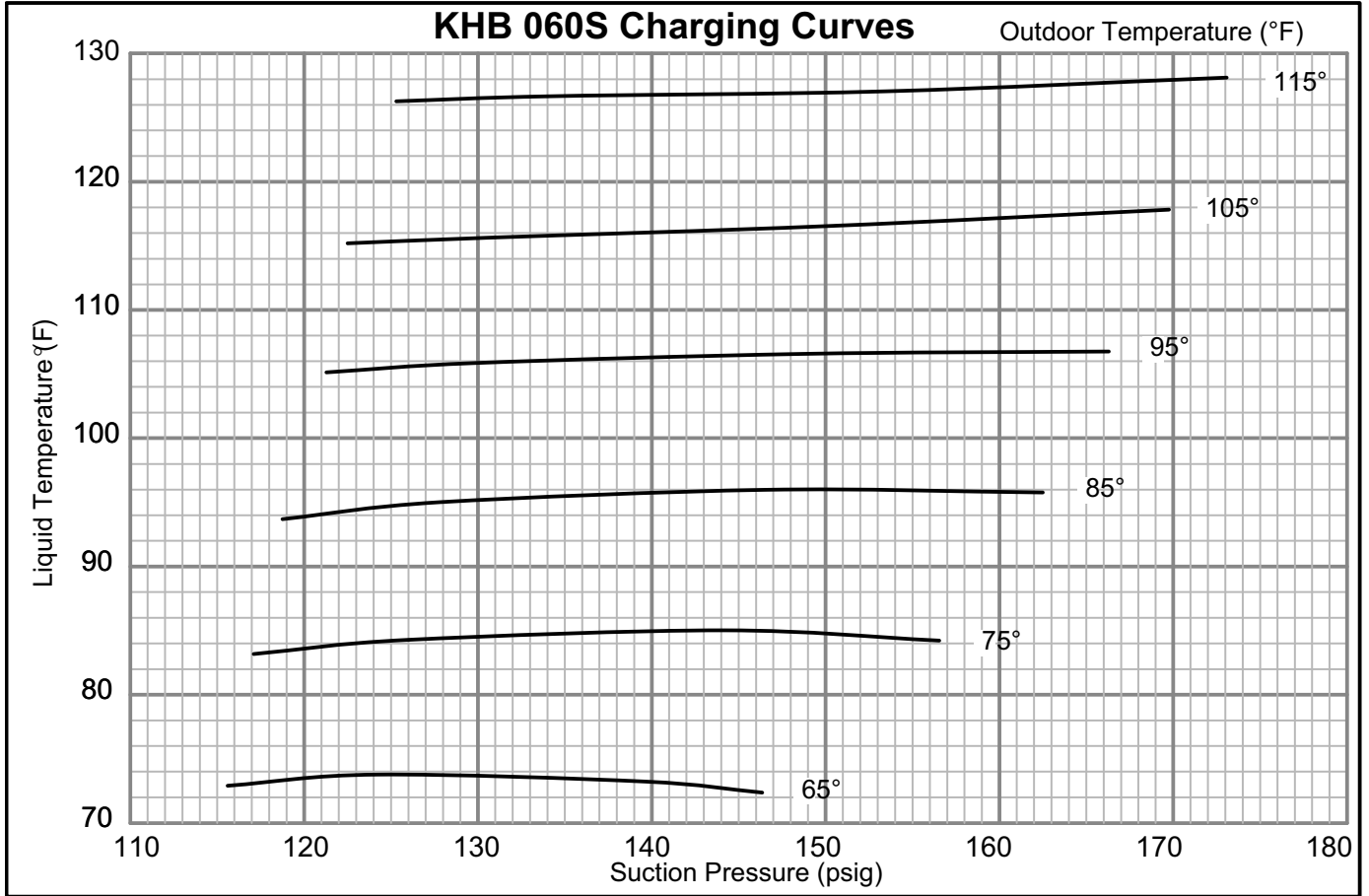
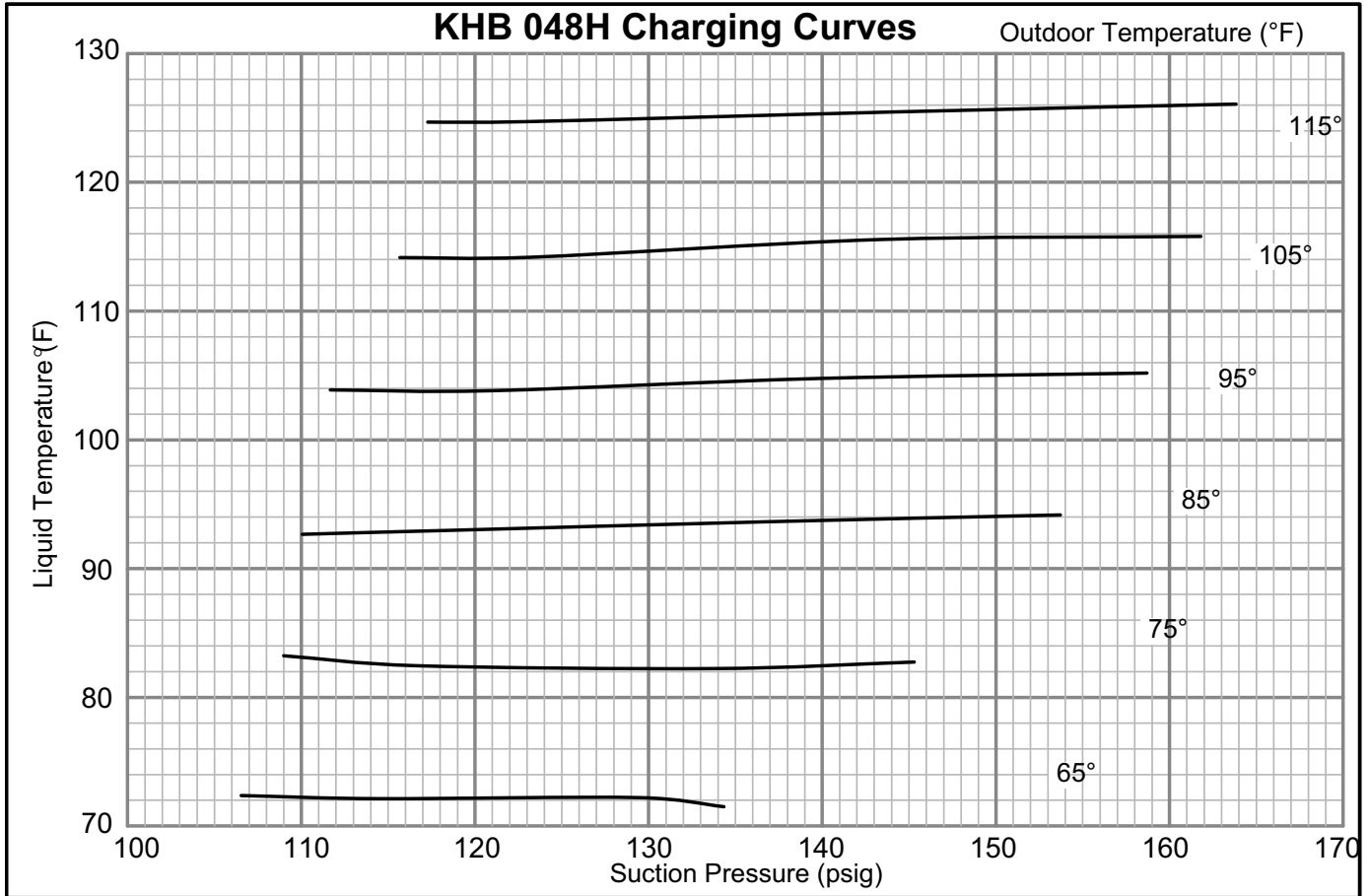

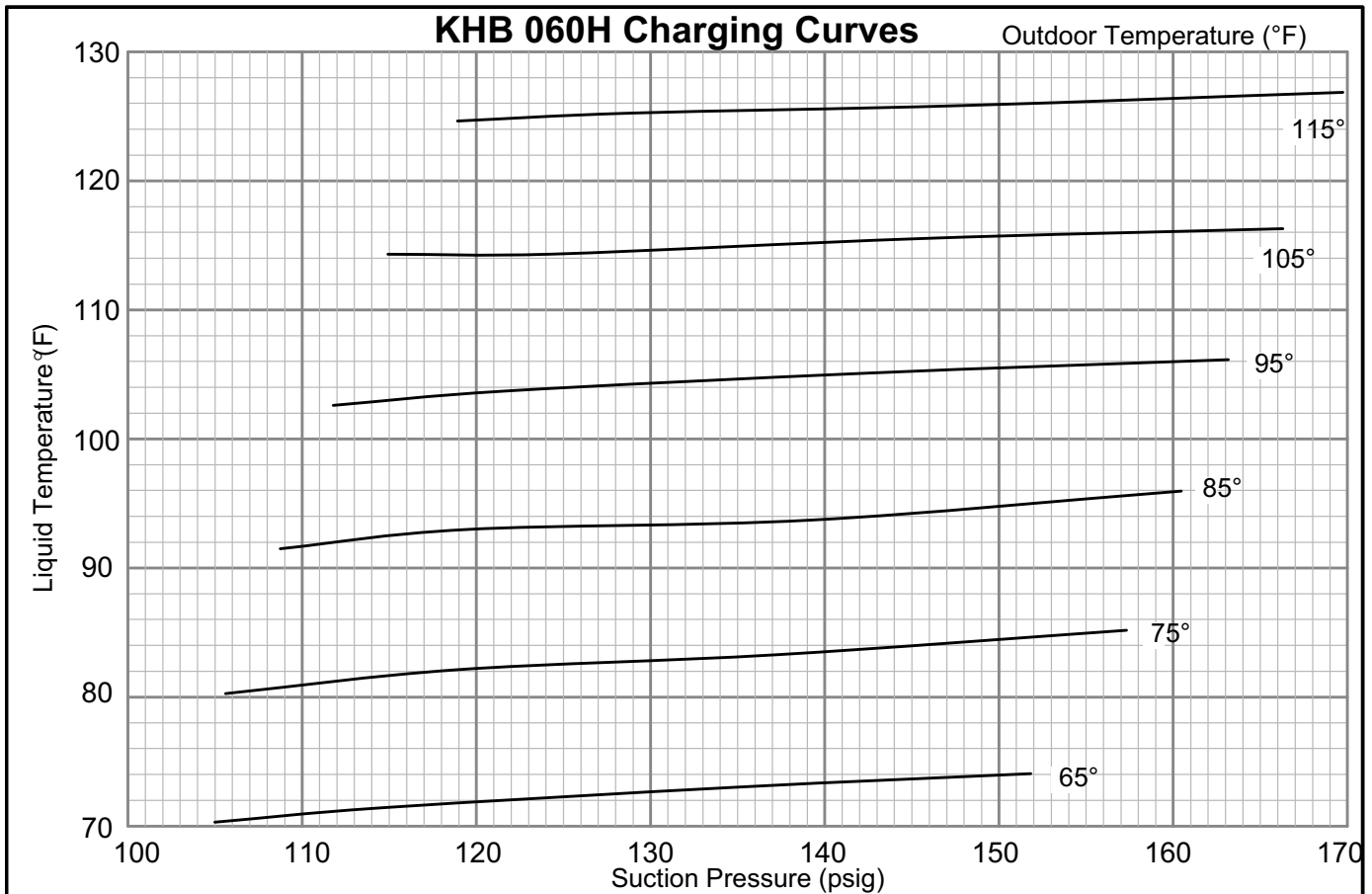

## F - Compressor Controls

See unit wiring diagram to determine which controls are used in each unit. Optional controls are identified on wiring diagrams by arrows at junction points.

### 1- Freezestat (S49)

Switch de-energizes compressor when indoor coil temperature falls below 29°F (-2°C) to prevent coil freeze-up. Switch resets when indoor coil temperature reaches 58°F (15°C).

### 2- High Pressure Switch (S4)

Auto-reset switch is located on the discharge line. Switch opens at 640 psig and closes at 475 psig. Switch is wired directly into the defrost control (CMC1), which provides a 5 strike lockout feature.

### 3- Defrost Switch (S6)

*100269 Series Only*

Defrost switch closes to initiate defrost when liquid line temperature falls to 42°F (5.6°C). Defrost switch opens when liquid line temperature reaches 70°F (21°C) to terminate defrost. If the liquid line temperature does not rise above 70°F (21°C), the CMC1 will terminate defrost after 14 minutes. The defrost switch is located on the liquid line between the outdoor expansion valve and the distributor

### 4- Ambient and Coil Temperature Sensors (RT13, RT21)

*100135 Series Only*

Both sensors provide input to the defrost control which cycles defrost. The ambient sensor is located on the inside of the corner mullion on the back of the outdoor coil section. The coil sensor is located on a return bend on the front of the outdoor coil.

### 5- Defrost Controls (CMC1)

Electric heat is energized during defrost to maintain discharge air temperature.

*100269 Series Time/Temperature*

When the liquid line temperature drops below 42°F (5.6°C), the defrost switch closes and signals the defrost control that a defrost cycle is needed. If the defrost switch is still closed after 90 minutes (default), a defrost cycle begins and operates for 14 minutes. The defrost switch can terminate the defrost cycle before the 14 minutes elapses if liquid line temperature reaches 70°F (21°C).

*Note - The defrost control will not energize a defrost cycle unless the unit has been operating in heating mode for an accumulated 90 minutes (default) on 100269 series boards. The run time interval can be changed by moving the jumper on the CMC board timing pins. See figure 19. The defrost interval can be adjusted to 30, 60, or 90 minutes. If the timing selector jumper is not in place, the control defaults to a 90-minute defrost interval.*

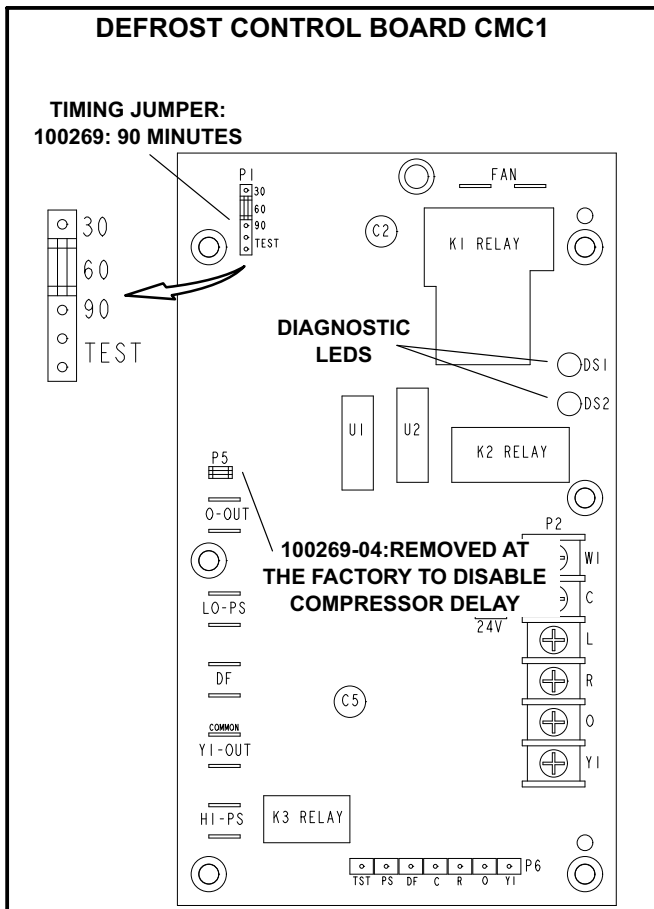

FIGURE 19

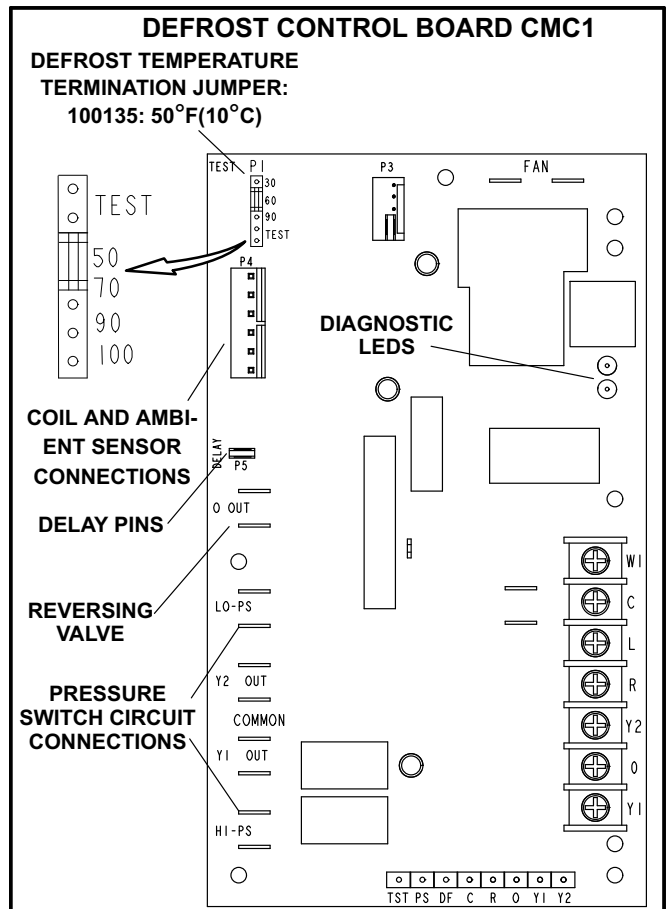

FIGURE 20

5- Defrost Controls (CMC1) - Continued

*100135 Series Demand Defrost Control*

After 34 minutes of heating mode operation, if the difference between the ambient temperature (RT13) and the coil temperature (RT21) is higher than the maximum difference allowed by the control, the defrost control will initiate defrost. The defrost control will also initiate defrost after 6 hours of heating mode operation when coil temperatures remain below 35°F (2°C). The defrost cycle ends when the coil temperature is higher than the termination temperature (50°F default) or after 14 minutes of operation. If the defrost is terminated by the 14-minute timer, another defrost cycle will be initiated after 34 minutes of run time.

*Note - The defrost termination temperature can be adjusted to 50, 70, 90 or 100 °F. The jumper termination pin is factory-set at 50 °F (10 °C). If the temperature jumper is not installed, the default termination temperature is 90 °F (32 °C). See figure 20.*

**Defrost Control Board**

The defrost control ensures that the heat pump outdoor coil does not ice excessively during the heating mode. The defrost control uses input from a defrost switch on 100269 series defrost control boards. The defrost control uses input from a coil and an ambient temperature sensor on 100135 series defrost control boards.

**Defrost Test Option**

A TEST option is provided for troubleshooting. The TEST mode may be started any time the unit is in the heating mode and the defrost thermostat is closed or jumpered. If the timing jumper is in the TEST position at power-up, the defrost control will ignore the test pins. When the jumper is placed across the TEST pins for two seconds, the control will enter the defrost mode. If the jumper is removed before an additional 5-second period has elapsed (7 seconds total), the unit will remain in defrost mode until the defrost pressure switch opens or 14 minutes have passed. If the jumper is not removed until after the additional 5-second period has elapsed, the defrost will terminate and the test option will not function again until the jumper is removed and re-applied.



## Diagnostic LEDs

The defrost board uses two LEDs for diagnostics. The LEDs flash a sequence according to the condition.

**TABLE 21**

Defrost Control Board Diagnostic LED		
Mode	Green LED (DS2)	Red LED (DS1)
No power to control	OFF	OFF
Normal operation / power to control	Simultaneous Slow FLASH	
Anti-short cycle lockout	Alternating Slow FLASH	
Low pressure switch, freezestat fault	OFF	Slow FLASH
Low pressure switch, freezestat lockout	OFF	ON
High pressure switch fault	Slow FLASH	OFF
High pressure switch lockout	ON	OFF
*Ambient sensor fault	Simultaneous FAST flash	
*Coil sensor fault	Alternating FAST flash	

\*100135 board only

## Service

The unit should be inspected once a year by a qualified service technician.

### **⚠ WARNING**

This product contains a chemical known to the State of California to cause cancer, birth defects, or other reproductive harm.

### **⚠ CAUTION**

Label all wires prior to disconnection when servicing controls. Wiring errors can cause improper and dangerous operation. Verify proper operation after servicing.

## A - Lubrication

All motors are lubricated at the factory. No further lubrication is required.

## B - Supply Air Blower Wheel

Annually inspect supply air blower wheel for accumulated dirt or dust. Turn off power before attempting to remove access panel or to clean blower wheel.

## C - Filters

Units are equipped with temporary filters which need to be replaced before the building is occupied. See table 22 for correct filter size. Refer to local codes or appropriate jurisdiction for approved filters.

Approved filters should be checked monthly and replaced when necessary. Take note of air flow direction marking on filter frame when reinstalling filters. See figure 21.

### **⚠ WARNING**

Units are shipped from the factory with temporary filters. Replace filters before building is occupied. Damage to unit could result if filters are not replaced with approved filters. Refer to appropriate codes.

**TABLE 22  
UNIT FILTERS**

Unit	Qty	Filter Size - inches (mm)
KHA036, 048 KHB024, 030, 036	4	16 X 20 X 2 (406 X 508 X 51)
KHA060, 072 KHB048, 060, 074	4	20 X 20 X 2 (508 X 508 X 51)

*NOTE-Filters must be U.L.C. certified or equivalent for use in Canada.*

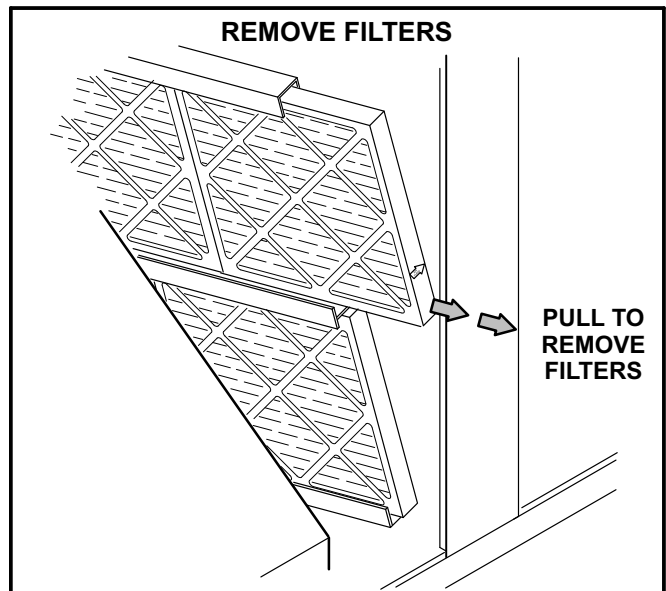

**FIGURE 21**

### D - Indoor Coil

Inspect and clean coil at beginning of each cooling and heating season. Clean using mild detergent or commercial coil cleanser. Flush coil and condensate drain with water taking care not to get insulation, filters and return air ducts wet.

### E - Filter Drier

The unit is equipped with a bi-flow filter drier. If replacement is necessary, order another of like design.

### F - Outdoor Coil

Clean outdoor coil annually with detergent or commercial coil cleaner and inspect monthly during the cooling season.

Outdoor coils are made of single and two formed slabs. On units with two slabs, dirt and debris may become trapped between the slabs. To clean between slabs, carefully separate coil slabs and wash them thoroughly. See figure 22. Flush coils with water following cleaning.

*Note - Remove all screws and gaskets prior to cleaning procedure and replace upon completion.*

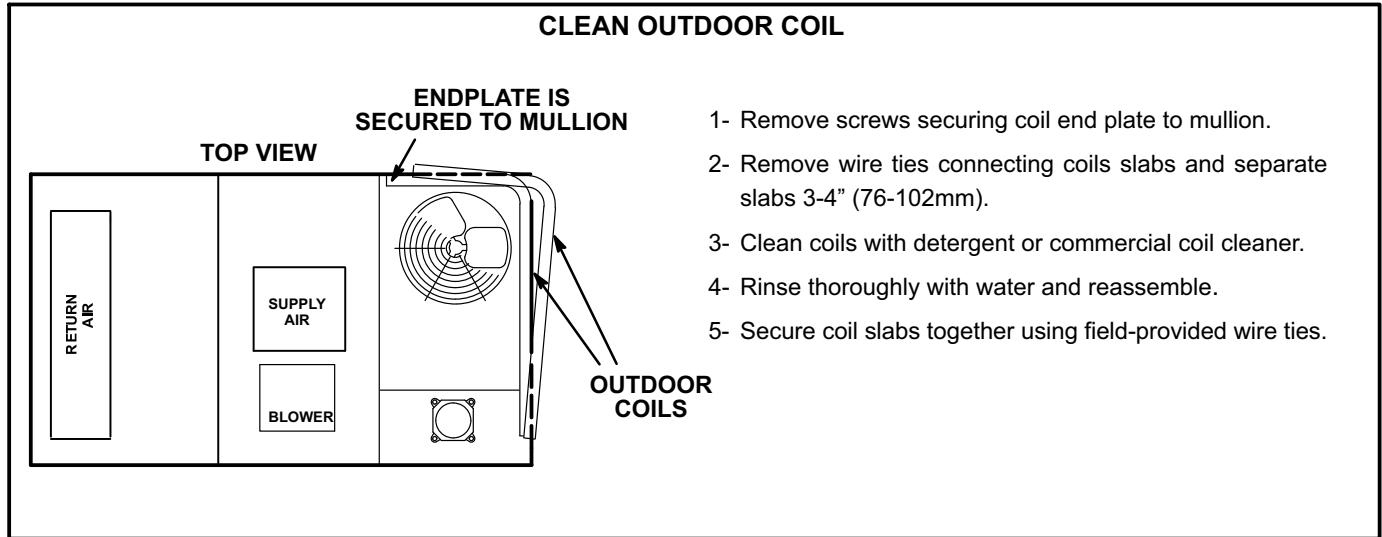

**FIGURE 22**