

INSTALLATION INSTRUCTIONS

⚠ WARNING

Improper installation, adjustment, alteration, service or maintenance can cause property damage, personal injury or loss of life. Installation and service must be performed by a qualified installer, service agency or the gas supplier

ZHA036 (3 TON) ZHA048 (4 TON) ZHA060 (5 TON)

RETAIN THESE INSTRUCTIONS FOR FUTURE REFERENCE

HEAT PUMP PACKAGED UNITS
507111-01
10/2012
Supersedes 506002-01

Table Of Contents

| | |
|---------------------------------|--------|
| Dimensions | Page 2 |
| Shipping and Packing List | Page 3 |
| General | Page 3 |
| Requirements | Page 3 |
| Unit Support | Page 4 |
| Duct Connection | Page 4 |
| Rigging Unit For Lifting | Page 4 |

| | |
|--|---------|
| Horizontal Air Discharge | Page 5 |
| Condensate Drains | Page 5 |
| Electrical Connections | Page 6 |
| Blower Operation and Adjustments | Page 6 |
| Start-Up | Page 13 |
| Defrost Control Board | Page 17 |
| Service | Page 18 |

ZHA036, 048, 060 PARTS ARRANGEMENT

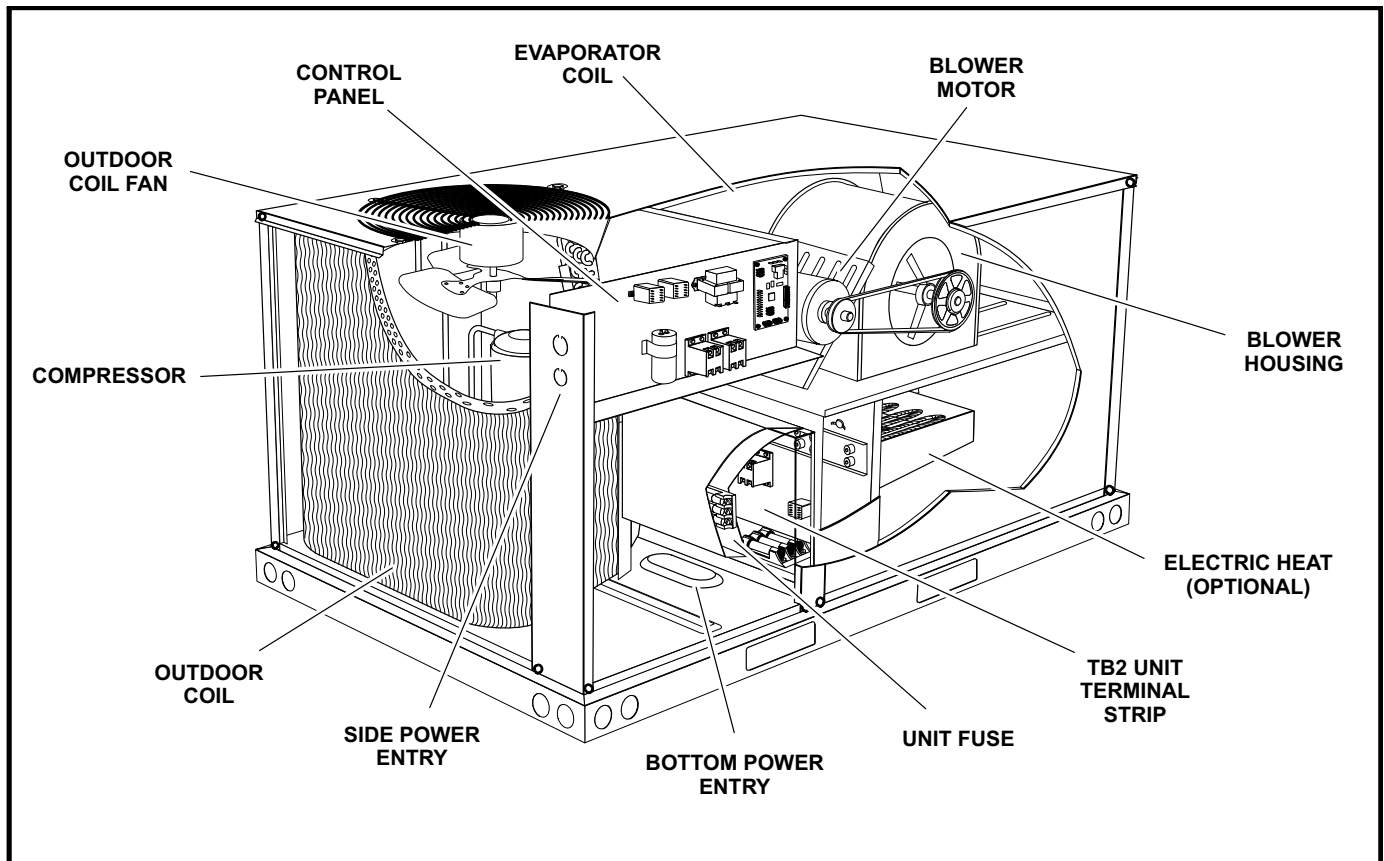

ZHA036, 048, 060, DIMENSIONS in (mm)

BOTTOM POWER ENTRY

Holes required for Optional Bottom Power Entry Kit

| | Threaded Conduit Fittings (Provided in Kit) | Wire Use | Hole Diameter Required in Unit Base (Max.) |
|----------|---|----------|--|
| A | 1/2 | ACC. | 7/8 (23) |
| B | 1/2 | 24V | 7/8 (23) |
| C | 3/4 | POWER | 1-1/8 (29) |

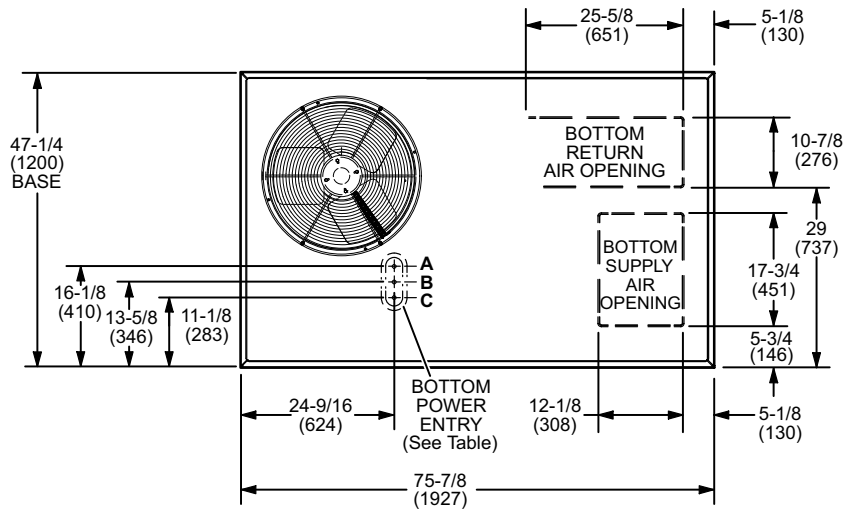

TOP VIEW (Base)

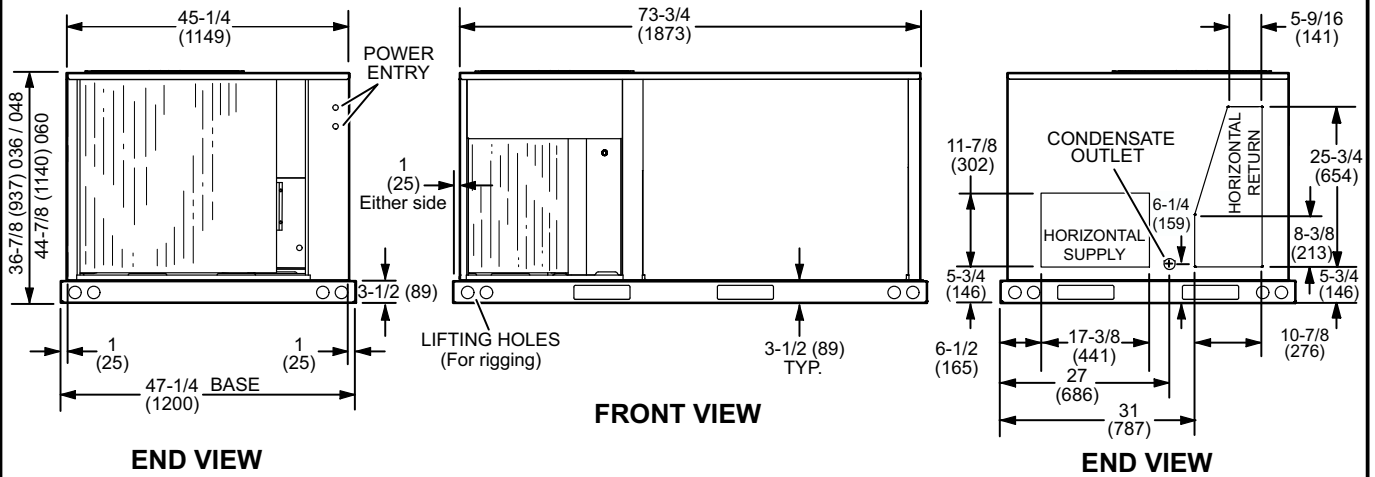

END VIEW

FRONT VIEW

END VIEW

Shipping and Packing List

Package 1 of 1 contains:

1 - Assembled unit

Check unit for shipping damage. Receiving party should contact last carrier immediately if shipping damage is found.

General

These instructions are intended as a general guide and do not supersede local codes in any way. Authorities having jurisdiction should be consulted before installation.

Availability of units and options varies by brand.

Requirements

The ZHA unit is CSA certified as a heat pump with cooling and with or without auxiliary electric heat for non-residential use only at the clearances to combustible materials as listed on the unit nameplate and in figure 1.

Installation of ZHA heat pumps must conform with standards in National Fire Protection Association (NFPA) "Standard for Installation of Air Conditioning and Ventilating Systems NFPA No. 90A," "Standard for Installation of Residence Type Warm Air Heating and Air conditioning Systems NFPA No. 90B," local municipal building codes and manufacturer's installation instructions.

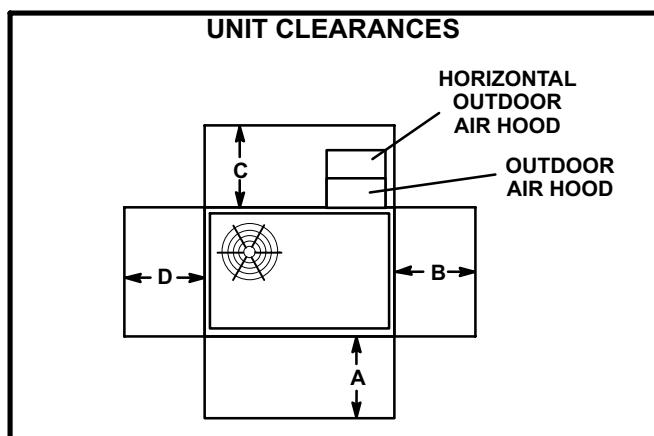

FIGURE 1

| ¹ Unit Clearance | A in.(mm) | B in.(mm) | C in.(mm) | D in.(mm) | Top Clearance |
|-----------------------------|--------------|--------------|--------------|--------------|---------------|
| Service Clearance | 36 (914) | 36 (914) | 36* (914) | 36 (914) | Unobstructed |
| Minimum Operation Clearance | 36 (914) | 36 (914) | 36* (914) | 36 (914) | Unobstructed |

*Clearance is 60 in. (1524mm) in horizontal air flow applications.

Note - Entire perimeter of unit base requires support when elevated above mounting surface.

¹ **Service Clearance** - Required for removal of serviceable parts.

Minimum Operation Clearance - Required clearance for proper unit operation.

⚠ NOTICE

Roof Damage!

This system contains both refrigerant and oil. Some rubber roofing material may absorb oil, causing the rubber to swell. Bubbles in the rubber roofing material can cause leaks. Protect the roof surface to avoid exposure to refrigerant and oil during service and installation. Failure to follow this notice could result in damage to roof surface.

The National Electric Code (ANSI/NFPA No. 70-1984) is available from:

National Fire Protection Association
1 Batterymarch Park
PO Box 9101
Quincy, MA 02269-9101

Installation of CSA certified units must also conform with current standard C273.5 "Installation Requirements for Heat Pumps" and applicable local codes. Authorities having jurisdiction should be consulted before installation.

Use of this unit as a construction heater or air conditioner is not recommended during any phase of construction. Very low return air temperatures, harmful vapors and operation of the unit with clogged or misplaced filters will damage the unit.

If this unit has been used for heating or cooling of buildings or structures under construction, the following conditions must be met or the warranty will be void:

- A room thermostat must control the unit. The use of fixed jumpers that will provide continuous heating or cooling is not allowed.
- A pre-filter must be installed at the entry to the return air duct.
- The return air duct must be provided and sealed to the unit.
- Return air temperature range between 55°F (13°C) and 80°F (27°C) must be maintained.
- Air filters must be replaced and pre-filter must be removed upon construction completion.
- The unit components, duct system, air filters and evaporator coil must be thoroughly cleaned following final construction clean-up.
- The unit operating conditions (including airflow, cooling operation, and heating operation) must be verified according to these installation instructions.

⚠ CAUTION

Danger of sharp metallic edges. Can cause injury. Take care when servicing unit to avoid accidental contact with sharp edges.

⚠ WARNING



Electric shock hazard and danger of explosion. Can cause injury, death or product or property damage. Turn off electrical power to unit before performing any maintenance or servicing operations on the unit.

⚠ IMPORTANT

The Clean Air Act of 1990 bans the intentional venting of refrigerant (CFC's and HCFC's) as of July 1, 1992. Approved methods of recovery, recycling or reclaiming must be followed. Fines and/or incarceration may be levied for non-compliance.

Unit Support

NOTE - Securely fasten roof frame to roof per local codes.

ZH 036, 048, 060 units are installed on Z1CURB frames.

A - Downflow Discharge Application

Roof Mounting with Z1CURB

- 1- The Z1CURB roof mounting frame must be installed, flashed and sealed in accordance with the instructions provided with the frame.
- 2- The Z1CURB roof mounting frame should be square and level to 1/16" per linear foot (5mm per linear meter) in any direction.
- 3- Duct must be attached to the roof mounting frame and not to the unit; supply and return plenums must be installed before setting the unit.

Installer's Roof Mounting Frame

Many types of roof frames can be used to install the unit, depending upon different roof structures. Items to keep in mind when using the building frame or supports are:

- 1- The unit base is fully enclosed and not insulated, so an enclosed, insulated frame is required.
- 2- The frames or supports must be constructed with non-combustible materials and should be square and level to 1/16" per linear foot (5mm per linear meter) in any direction.
- 3- Frame or supports must be high enough to prevent any form of moisture from entering unit. Recommended minimum frame height is 14" (356mm).
- 4- Duct must be attached to the roof mounting frame and not to the unit. Supply and return plenums must be installed before setting the unit.
- 5- Units require support along all four sides of unit base. Supports must be constructed of steel or suitably treated wood materials.

NOTE-When installing unit on a combustible surface for downflow discharge applications, the Z1CURB roof mounting frame is required.

B - Horizontal Discharge Applications

- 1- Specified installation clearances must be maintained when installing units. Refer to figure 1.
- 2- Top of support slab should be at least 4" (102mm) above the finished grade and located so no run-off water from higher ground can collect around the unit.
- 3- Units require support along all four sides of unit base. Supports must be constructed of steel or suitably treated wood materials.

Duct Connection

All exterior ducts, joints, and openings in roof or building walls must be insulated and weatherproofed with flashing and sealing compounds in accordance with applicable codes. Any duct passing through an unconditioned space must be insulated.

⚠ CAUTION

In downflow applications, do not drill or punch holes in base of unit. Leaking in roof may occur if unit base is punctured.

Rigging Unit For Lifting

- 1- Connect rigging to the unit base using both holes in each corner. See figure 2.
- 2- All panels must be in place for rigging.
- 3- Place field-provided H-style pick in place just above top edge of unit. Frame must be of adequate strength and length. (H-style pick prevents damage to unit.)

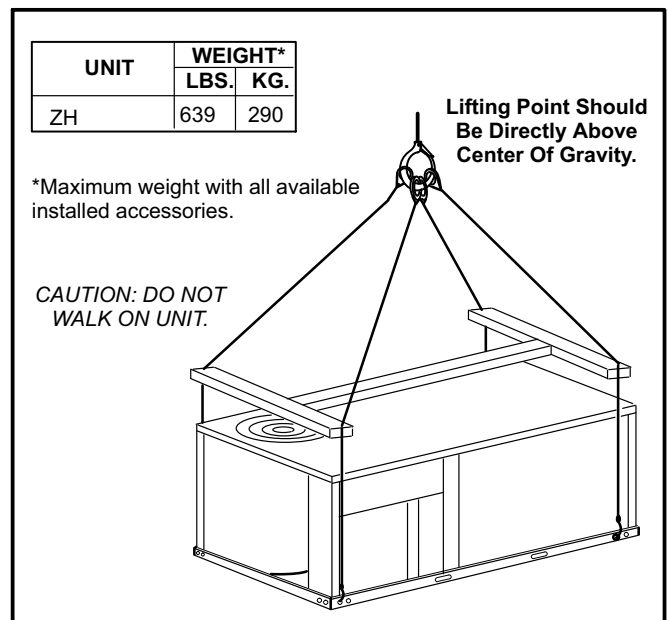

FIGURE 2

Horizontal Air Discharge

Unit is shipped with panels covering the horizontal supply and return air openings. See figure 3.

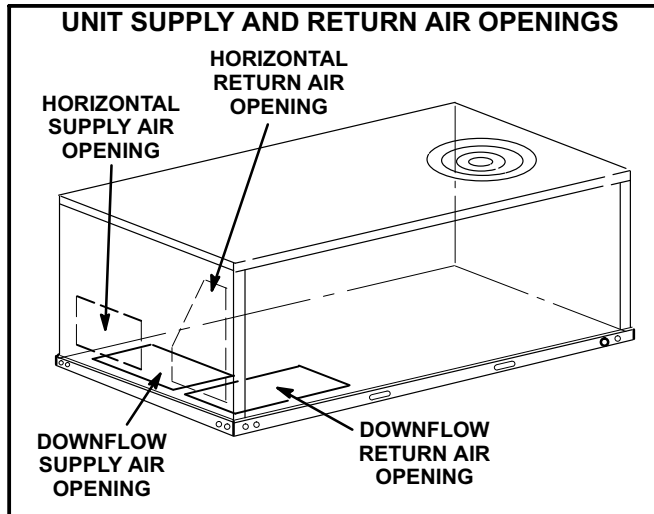

FIGURE 3

- 1- Remove horizontal covers and place a bead of silicone sealant on the underside of the duct cover flanges. See figure 4.
- 2- Position covers over downflow openings. Secure covers with self-drilling screws in at least two places on each cover. Drill through duct cover side into flange of base pan.
- 3- Place a bead of silicone between insulation and duct cover to seal in insulation edges. Let silicone dry before running gas or electric heat.

Units Equipped With An Optional Horizontal Economizer

- 1- Install the horizontal supply air cover over the down flow supply air opening as described above.
- 2- Leave the horizontal return air cover in place.
- 3- Locate the extra horizontal return cover that is included with the horizontal economizer kit. Install as described in previous section.

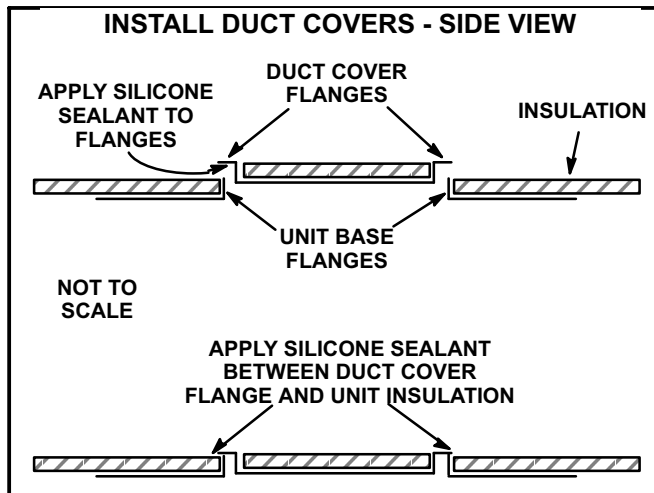

FIGURE 4

- 4- Install return air duct on the intake air side of the horizontal economizer. See figure 5.
- 5- Horizontal economizer and return air duct must be field-supported.

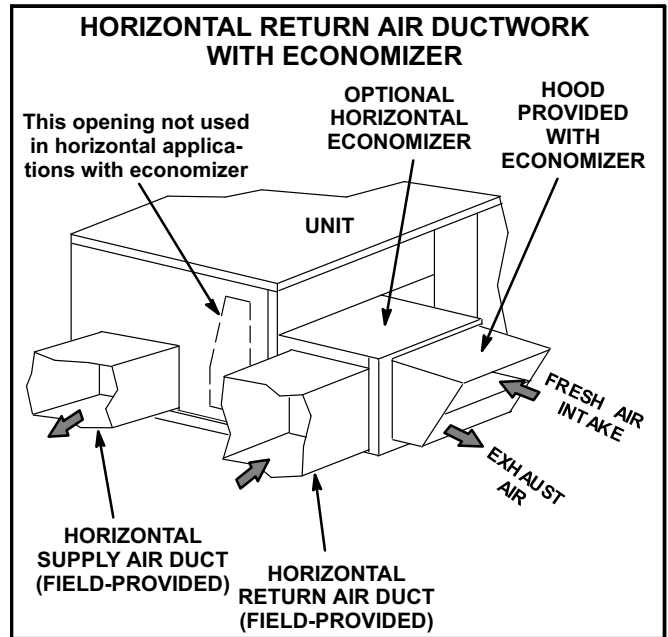

FIGURE 5

Condensate Drains

Make drain connection to the drain coupling provided on unit.

Note - The drain pan is made with a glass reinforced engineered plastic capable of withstanding typical joint torque but can be damaged with excessive force. Tighten pipe nipple hand tight and turn an additional quarter turn.

A trap must be installed between drain connection and an open vent for proper condensate removal. See figure 6. It is sometimes acceptable to drain condensate onto the roof or grade; however, a tee should be fitted to the trap to direct condensate downward. The condensate line must be vented. Check local codes concerning condensate disposal. Refer to pages 1 and 2 for condensate drain location.

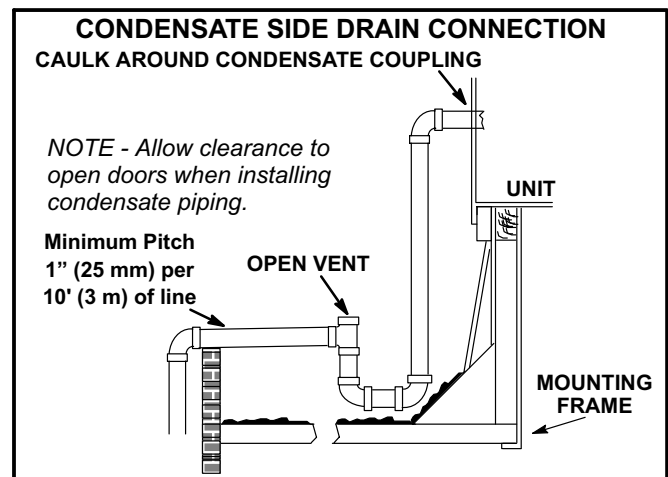

FIGURE 6

Electrical Connections

POWER SUPPLY

Do not apply power or close disconnect switch until installation is complete. Refer to start-up directions. Refer closely to unit wiring diagram.

Refer to unit nameplate for minimum circuit ampacity and maximum fuse size.

- 1- Units are factory-wired for 240,460,575 volt supply. **For 208V supply**, remove the insulated terminal cover from the 208V terminal on the control transformer. Move the wire from the transformer 240V terminal to the 208V terminal. Place the insulated terminal cover on the unused 240V terminal.
- 2- Route power through the side or bottom power entry area. For bottom power entry, a bottom power entry kit must be used. Connect power wiring to power wire leads in control box. On units equipped with electric heat, route power wiring to TB2; see parts arrangement for location. See unit wiring diagram.

CONTROL WIRING

A - Thermostat Location

Room thermostat mounts vertically on a standard 2" X 4" handy box or on any non-conductive flat surface.

Locate thermostat approximately 5 feet (1524 mm) above the floor in an area with good air circulation at average temperature. Avoid locating the room thermostat where it might be affected by:

- drafts or dead spots behind doors and in corners
- hot or cold air from ducts
- radiant heat from sun or appliances
- concealed pipes and chimneys

IMPORTANT - Unless field thermostat wires are rated for maximum unit voltage, they must be routed away from line voltage wiring.

B - Control Wiring

- 1- Route thermostat cable or wires from subbase to control panel (refer to unit dimensions to locate bottom and side power entry).
Use 18 AWG wire for all applications using remotely installed electro-mechanical and electronic thermostats.
- 2- Install thermostat assembly in accordance with instructions provided with thermostat.
- 3- Connect thermostat wiring to low voltage leads in control box. Wire as shown in figure 7 for

electro-mechanical and electronic thermostats. If using other temperature control devices or energy management systems see instructions and wiring diagram provided by manufacturer.

IMPORTANT-Terminal connections at the wall plate or subbase must be made securely. Loose control wire connections may allow unit to operate but not with proper response to room demand.

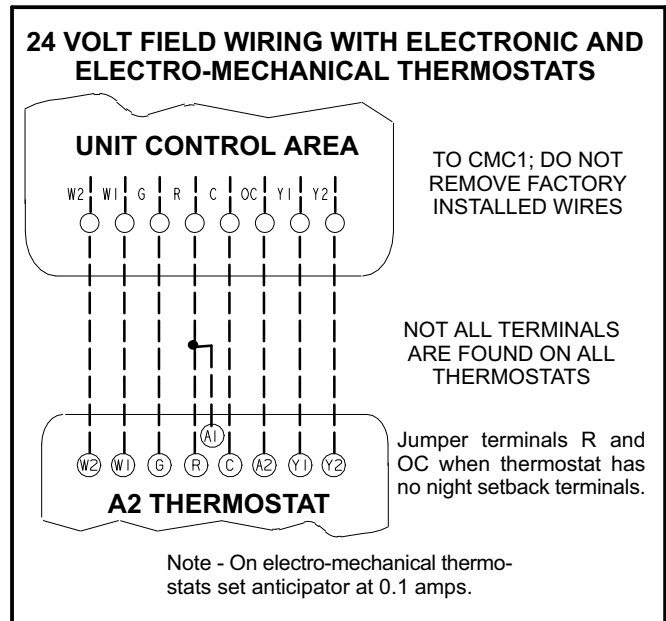

FIGURE 7

Blower Operation and Adjustments

Units are equipped with belt drive blowers; available drive varies by model.

▲ IMPORTANT

Three phase scroll compressors must be phased sequentially for correct compressor and blower rotation. Follow "COOLING START-UP" section of installation instructions to ensure proper compressor and blower operation.

A - Blower Operation

Initiate blower demand at thermostat according to instructions provided with thermostat. Unit will cycle on thermostat demand. The following steps apply to applications using a typical electro-mechanical thermostat.

- 1- Set thermostat or temperature control device fan switch to **AUTO** or **ON**. With fan switch in **ON** position, blower will operate continuously. With fan switch in **AUTO** position, the blower will cycle with demand.
- 2- Blower and entire unit will be off when thermostat or temperature control device system switch is in **OFF** position.

B - Determining Unit CFM

- 1- The following measurements must be made with air filters in place.
- 2- With all access panels in place, measure static pressure external to unit (from supply to return). Blower performance data is based on static pressure readings taken in locations shown in figure 8.

Note - Static pressure readings can vary if not taken where shown.

- 3- Measure the indoor blower wheel RPM.
- 4- Referring to pages 9-11, use static pressure and RPM readings to determine unit CFM. Use option/accessory air resistance table on page 12

when installing units with any of the options or accessories listed. Refer to table 3 for minimum airflow when electric heat is installed.

- 5- The blower RPM can be adjusted at the motor pulley. Loosen Allen screw and turn adjustable pulley clockwise to increase CFM. Turn counterclockwise to decrease CFM. See figure 9. Do not exceed minimum and maximum number of pulley turns as shown in table 1.

**TABLE 1
MINIMUM AND MAXIMUM PULLEY ADJUSTMENT**

| Belt | Min. Turns Open | Maxi. Turns Open |
|-----------|-----------------|------------------|
| A Section | No minimum | 5 |

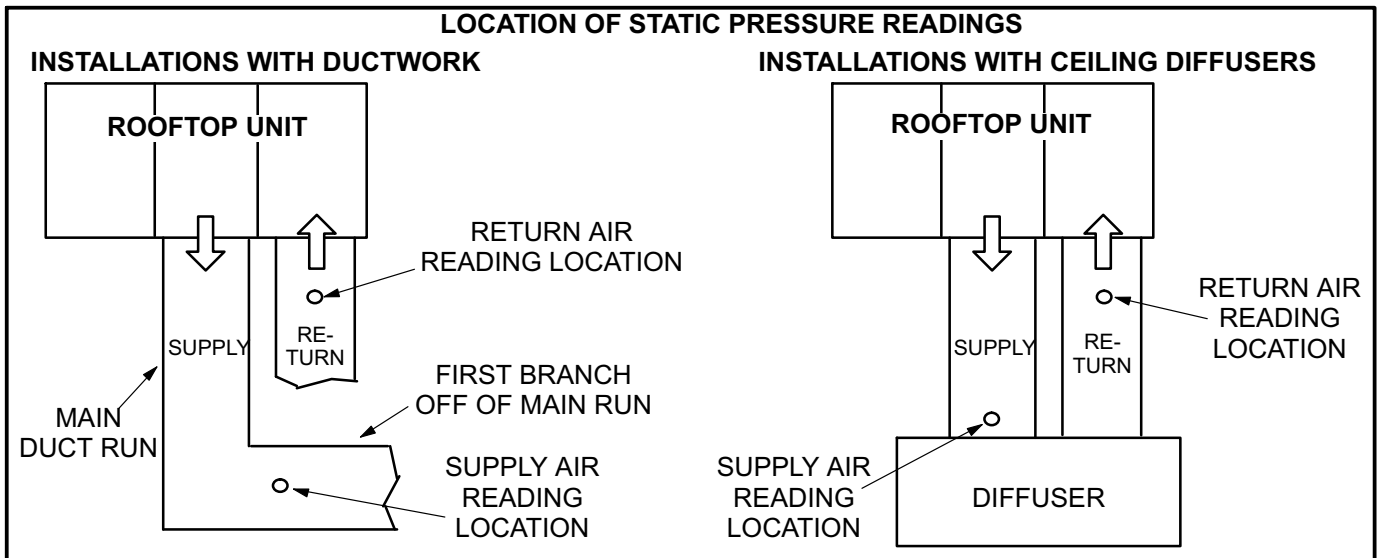

FIGURE 8

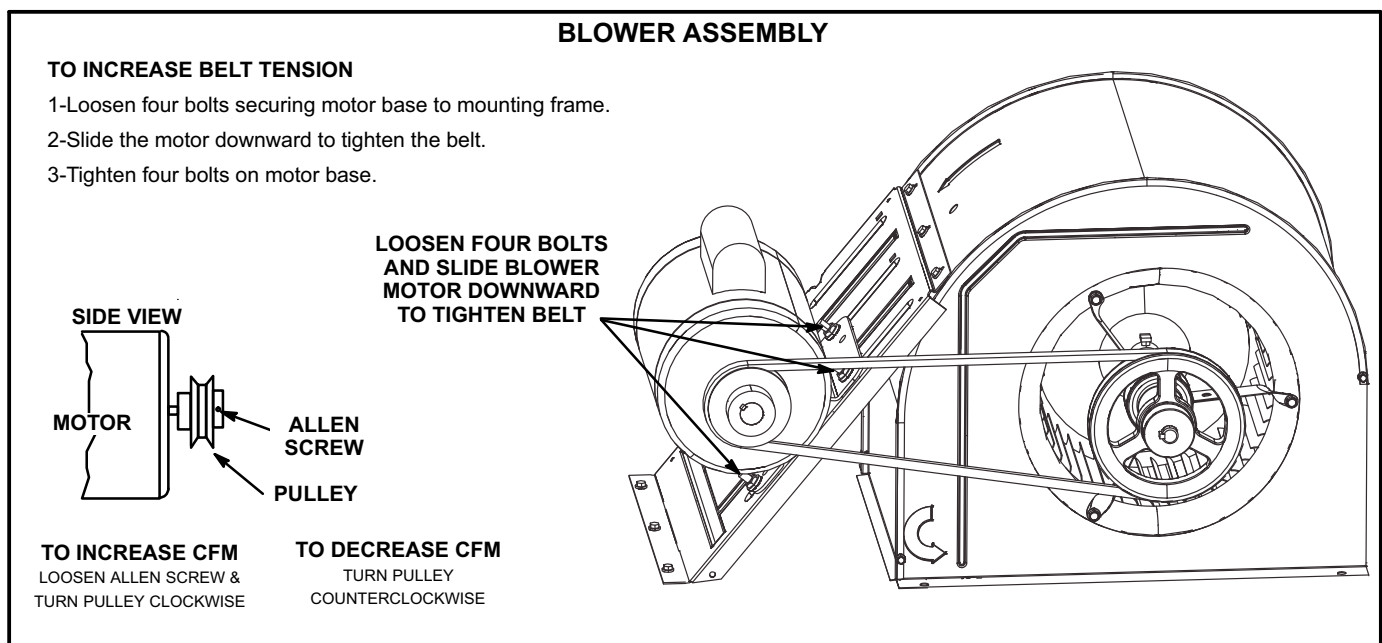

FIGURE 9

D - Blower Belt Adjustment

Maximum life and wear can be obtained from belts only if proper pulley alignment and belt tension are maintained. Tension new belts after a 24-48 hour period of operation. This will allow belt to stretch and seat grooves. Make sure blower and motor pulley are aligned as shown in figure 10.

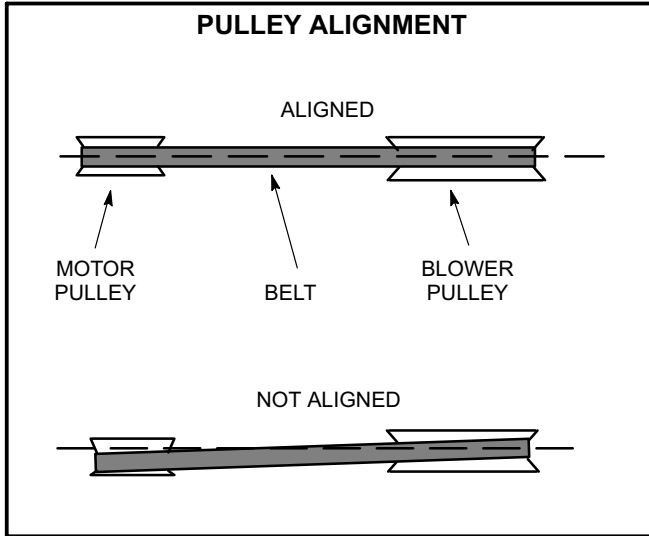

FIGURE 10

- 1- Loosen four bolts securing motor base to mounting frame. See figure 9.
- 2- *To increase belt tension -*
Slide blower motor downward to tighten the belt. This increases the distance between the blower motor and the blower housing.

To loosen belt tension -
Slide blower motor upward to loosen the belt. This decreases the distance between the blower motor and the blower housing.
- 3- Tighten four bolts securing motor base to the mounting frame.

E - Check Belt Tension

Overtensioning belts shortens belt and bearing life. Check belt tension as follows:

- 1- Measure span length X. See figure 11.
- 2- Apply perpendicular force to center of span (X) with enough pressure to deflect belt 1/64" for every inch of span length or 1.5mm per 100mm of span length.

Example: Deflection distance of a 40" span would be 40/64" or 5/8".

Example: Deflection distance of a 400mm span would be 6mm.

- 3- Measure belt deflection force. For a used belt, the deflection force should be 5 lbs. (35kPa). A new belt deflection force should be 7 lbs. (48kPa).

A force below these values indicates an undertensioned belt. A force above these values indicates an overtensioned belt.

F-Field-Furnished Blower Drives

For field-furnished blower drives, use pages 9-11 to determine BHP and RPM required. Reference drive kit specification table on page 12 to determine the drive kit number and table 2 for drive component manufacturer's numbers.

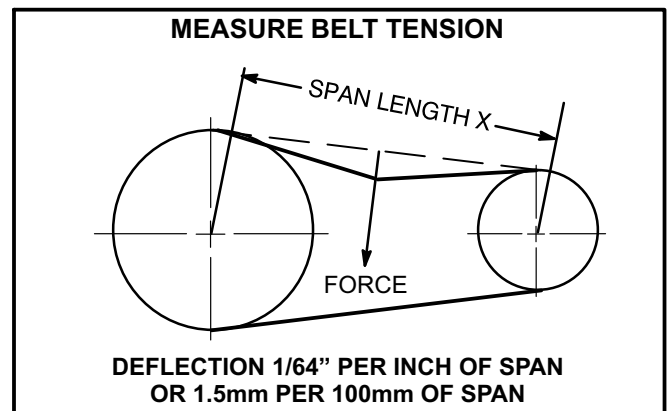

FIGURE 11

BLOWER DATA - BELT DRIVE - ZHA036

BLOWER TABLE INCLUDES RESISTANCE FOR BASE UNIT ONLY WITH DRY INDOOR COIL AND AIR FILTERS IN PLACE.

FOR ALL UNITS ADD:

1 - Any factory installed options air resistance (heat section, economizer, wet coil, etc.).

2 - Any field installed accessories air resistance (duct resistance, diffuser, etc.).

See page 12 for blower motors and drives and wet coil and options/accessory air resistance data.

DOWNFLOW

| Air Volume cfm | External Static - in. w.g. | | | | | | | | | | | | | | | |
|-------------------|----------------------------|------|------|------|---------|------|------|------|------|------|------|------|------|------|------|------|
| | 0.10 | | 0.20 | | 0.30 | | 0.40 | | 0.50 | | 0.60 | | 0.70 | | 0.80 | |
| | RPM | BHP | RPM | BHP | RPM | BHP | RPM | BHP | RPM | BHP | RPM | BHP | RPM | BHP | RPM | BHP |
| | Field Furnished | | | | Kit Z01 | | | | | | | | | | | |
| 900 | 562 | 0.16 | 629 | 0.18 | 699 | 0.19 | 771 | 0.2 | 840 | 0.22 | 904 | 0.24 | 962 | 0.26 | 1015 | 0.29 |
| 1000 | 586 | 0.18 | 654 | 0.2 | 725 | 0.21 | 796 | 0.23 | 864 | 0.25 | 927 | 0.27 | 983 | 0.3 | 1034 | 0.33 |
| 1100 | 612 | 0.2 | 681 | 0.22 | 752 | 0.24 | 823 | 0.26 | 890 | 0.28 | 950 | 0.31 | 1004 | 0.34 | 1054 | 0.37 |
| 1200 | 641 | 0.23 | 711 | 0.25 | 783 | 0.27 | 852 | 0.29 | 917 | 0.32 | 975 | 0.35 | 1027 | 0.39 | 1074 | 0.42 |
| 1300 | 673 | 0.25 | 744 | 0.28 | 815 | 0.3 | 882 | 0.33 | 944 | 0.36 | 1000 | 0.4 | 1050 | 0.44 | 1096 | 0.48 |
| 1400 | 709 | 0.29 | 779 | 0.32 | 849 | 0.34 | 914 | 0.37 | 973 | 0.41 | 1026 | 0.45 | 1074 | 0.49 | 1118 | 0.53 |
| 1500 | 747 | 0.33 | 816 | 0.36 | 883 | 0.39 | 945 | 0.42 | 1001 | 0.46 | 1052 | 0.51 | 1098 | 0.55 | 1141 | 0.59 |

| Air Volume cfm | External Static - in. w.g. | | | | | | | | | | | | | | | |
|-------------------|----------------------------|------|------|------|------|------|------|------|------|------|------|------|------|------|------|------|
| | 0.90 | | 1.00 | | 1.10 | | 1.20 | | 1.30 | | 1.40 | | 1.50 | | 1.60 | |
| | RPM | BHP | RPM | BHP | RPM | BHP | RPM | BHP | RPM | BHP | RPM | BHP | RPM | BHP | RPM | BHP |
| | Kit Z04 | | | | | | | | | | | | | | | |
| 900 | 1065 | 0.32 | 1112 | 0.35 | 1158 | 0.38 | 1202 | 0.41 | 1243 | 0.44 | 1284 | 0.48 | 1323 | 0.52 | 1364 | 0.55 |
| 1000 | 1082 | 0.36 | 1128 | 0.39 | 1173 | 0.42 | 1216 | 0.45 | 1257 | 0.49 | 1297 | 0.53 | 1336 | 0.57 | 1375 | 0.6 |
| 1100 | 1100 | 0.4 | 1145 | 0.44 | 1189 | 0.47 | 1231 | 0.51 | 1272 | 0.54 | 1311 | 0.58 | 1349 | 0.62 | 1388 | 0.66 |
| 1200 | 1119 | 0.45 | 1163 | 0.49 | 1206 | 0.52 | 1247 | 0.56 | 1287 | 0.6 | 1326 | 0.64 | 1364 | 0.68 | 1402 | 0.72 |
| 1300 | 1139 | 0.51 | 1182 | 0.55 | 1224 | 0.58 | 1265 | 0.62 | 1304 | 0.66 | 1342 | 0.71 | 1379 | 0.75 | 1416 | 0.79 |
| 1400 | 1160 | 0.57 | 1202 | 0.61 | 1243 | 0.65 | 1283 | 0.69 | 1322 | 0.73 | 1359 | 0.78 | 1396 | 0.82 | 1432 | 0.87 |
| 1500 | 1182 | 0.64 | 1223 | 0.68 | 1263 | 0.72 | 1303 | 0.76 | 1341 | 0.81 | 1378 | 0.85 | 1414 | 0.9 | 1449 | 0.94 |

HORIZONTAL

| Air Volume cfm | External Static - in. w.g. | | | | | | | | | | | | | | | | | |
|-------------------|----------------------------|------|------|------|---------|------|------|------|------|------|------|------|------|------|------|------|---------|--|
| | 0.10 | | 0.20 | | 0.30 | | 0.40 | | 0.50 | | 0.60 | | 0.70 | | 0.80 | | | |
| | RPM | BHP | RPM | BHP | RPM | BHP | RPM | BHP | RPM | BHP | RPM | BHP | RPM | BHP | RPM | BHP | | |
| | Field Furnished | | | | Kit Z01 | | | | | | | | | | | | Kit Z04 | |
| 900 | 580 | 0.14 | 649 | 0.17 | 721 | 0.19 | 794 | 0.22 | 868 | 0.24 | 938 | 0.27 | 998 | 0.3 | 1045 | 0.33 | | |
| 1000 | 612 | 0.17 | 681 | 0.19 | 752 | 0.22 | 825 | 0.25 | 897 | 0.27 | 963 | 0.3 | 1017 | 0.33 | 1061 | 0.37 | | |
| 1100 | 647 | 0.2 | 717 | 0.23 | 788 | 0.26 | 858 | 0.28 | 926 | 0.31 | 986 | 0.34 | 1036 | 0.38 | 1077 | 0.41 | | |
| 1200 | 687 | 0.23 | 757 | 0.26 | 826 | 0.29 | 893 | 0.32 | 955 | 0.35 | 1008 | 0.39 | 1054 | 0.42 | 1095 | 0.46 | | |
| 1300 | 730 | 0.27 | 798 | 0.3 | 864 | 0.33 | 926 | 0.37 | 982 | 0.4 | 1030 | 0.44 | 1073 | 0.47 | 1116 | 0.51 | | |
| 1400 | 775 | 0.31 | 840 | 0.34 | 902 | 0.38 | 959 | 0.42 | 1009 | 0.46 | 1054 | 0.5 | 1096 | 0.53 | 1140 | 0.56 | | |
| 1500 | 820 | 0.36 | 881 | 0.4 | 939 | 0.44 | 993 | 0.49 | 1039 | 0.53 | 1082 | 0.56 | 1124 | 0.59 | 1168 | 0.62 | | |

| Air Volume cfm | External Static - in. w.g. | | | | | | | | | | | | | | | |
|-------------------|----------------------------|------|------|------|------|------|------|------|------|------|------|------|------|------|------|------|
| | 0.90 | | 1.00 | | 1.10 | | 1.20 | | 1.30 | | 1.40 | | 1.50 | | 1.60 | |
| | RPM | BHP | RPM | BHP | RPM | BHP | RPM | BHP | RPM | BHP | RPM | BHP | RPM | BHP | RPM | BHP |
| | Kit Z04 | | | | | | | | | | | | | | | |
| 900 | 1091 | 0.36 | 1140 | 0.38 | 1188 | 0.4 | 1232 | 0.43 | 1272 | 0.46 | 1309 | 0.49 | 1346 | 0.53 | 1383 | 0.57 |
| 1000 | 1105 | 0.4 | 1154 | 0.42 | 1201 | 0.45 | 1245 | 0.47 | 1284 | 0.5 | 1321 | 0.54 | 1357 | 0.58 | 1394 | 0.62 |
| 1100 | 1121 | 0.44 | 1169 | 0.47 | 1216 | 0.49 | 1259 | 0.52 | 1298 | 0.56 | 1335 | 0.6 | 1370 | 0.64 | 1406 | 0.69 |
| 1200 | 1139 | 0.49 | 1187 | 0.52 | 1234 | 0.54 | 1276 | 0.58 | 1314 | 0.62 | 1350 | 0.66 | 1385 | 0.71 | 1421 | 0.75 |
| 1300 | 1161 | 0.54 | 1208 | 0.57 | 1254 | 0.6 | 1295 | 0.64 | 1332 | 0.69 | 1366 | 0.73 | 1401 | 0.78 | 1436 | 0.83 |
| 1400 | 1185 | 0.59 | 1232 | 0.63 | 1276 | 0.67 | 1315 | 0.71 | 1351 | 0.76 | 1384 | 0.81 | 1419 | 0.86 | 1454 | 0.9 |
| 1500 | 1212 | 0.66 | 1257 | 0.7 | 1299 | 0.74 | 1337 | 0.79 | 1371 | 0.84 | 1404 | 0.89 | 1438 | 0.94 | 1473 | 0.99 |

BLOWER DATA - BELT DRIVE - ZHA048

BLOWER TABLE INCLUDES RESISTANCE FOR BASE UNIT ONLY WITH DRY INDOOR COIL AND AIR FILTERS IN PLACE.

FOR ALL UNITS ADD:

1 - Any factory installed options air resistance (heat section, economizer, wet coil, etc.).

2 - Any field installed accessories air resistance (duct resistance, diffuser, etc.).

See page 12 for blower motors and drives and wet coil and options/accessory air resistance data.

DOWNFLOW

| Air Volume cfm | External Static - in. w.g. | | | | | | | | | | | | | | | |
|-------------------|----------------------------|------|------|------|------|------|---------|------|------|------|------|------|------|------|------|------|
| | 0.10 | | 0.20 | | 0.30 | | 0.40 | | 0.50 | | 0.60 | | 0.70 | | 0.80 | |
| | RPM | BHP | RPM | BHP | RPM | BHP | RPM | BHP | RPM | BHP | RPM | BHP | RPM | BHP | RPM | BHP |
| | Field Furnished | | | | | | Kit Z02 | | | | | | | | | |
| 1200 | 641 | 0.23 | 711 | 0.25 | 783 | 0.27 | 852 | 0.29 | 917 | 0.32 | 975 | 0.35 | 1027 | 0.39 | 1074 | 0.42 |
| 1300 | 673 | 0.25 | 744 | 0.28 | 815 | 0.30 | 882 | 0.33 | 944 | 0.36 | 1000 | 0.40 | 1050 | 0.44 | 1096 | 0.48 |
| 1400 | 709 | 0.29 | 779 | 0.32 | 849 | 0.34 | 914 | 0.37 | 973 | 0.41 | 1026 | 0.45 | 1074 | 0.49 | 1118 | 0.53 |
| 1500 | 747 | 0.33 | 816 | 0.36 | 883 | 0.39 | 945 | 0.42 | 1001 | 0.46 | 1052 | 0.51 | 1098 | 0.55 | 1141 | 0.59 |
| 1600 | 787 | 0.38 | 854 | 0.41 | 918 | 0.44 | 976 | 0.48 | 1030 | 0.52 | 1078 | 0.56 | 1123 | 0.61 | 1164 | 0.66 |
| 1700 | 827 | 0.43 | 892 | 0.46 | 952 | 0.49 | 1007 | 0.53 | 1058 | 0.58 | 1105 | 0.63 | 1148 | 0.68 | 1189 | 0.73 |
| 1800 | 868 | 0.48 | 929 | 0.52 | 986 | 0.55 | 1038 | 0.59 | 1087 | 0.64 | 1132 | 0.69 | 1174 | 0.75 | 1214 | 0.80 |
| 1900 | 907 | 0.54 | 966 | 0.58 | 1019 | 0.62 | 1069 | 0.66 | 1116 | 0.71 | 1160 | 0.77 | 1200 | 0.82 | 1240 | 0.88 |
| 2000 | 946 | 0.60 | 1001 | 0.65 | 1053 | 0.69 | 1101 | 0.74 | 1146 | 0.79 | 1188 | 0.85 | 1228 | 0.91 | 1267 | 0.98 |

| Air Volume cfm | External Static - in. w.g. | | | | | | | | | | | | | | | |
|-------------------|----------------------------|------|------|------|------|------|---------|------|------|------|------|------|------|------|------|------|
| | 0.90 | | 1.00 | | 1.10 | | 1.20 | | 1.30 | | 1.40 | | 1.50 | | 1.60 | |
| | RPM | BHP | RPM | BHP | RPM | BHP | RPM | BHP | RPM | BHP | RPM | BHP | RPM | BHP | RPM | BHP |
| | Kit Z02 | | | | | | Kit Z05 | | | | | | | | | |
| 1200 | 1119 | 0.45 | 1163 | 0.49 | 1206 | 0.52 | 1247 | 0.56 | 1287 | 0.60 | 1326 | 0.64 | 1364 | 0.68 | 1402 | 0.72 |
| 1300 | 1139 | 0.51 | 1182 | 0.55 | 1224 | 0.58 | 1265 | 0.62 | 1304 | 0.66 | 1342 | 0.71 | 1379 | 0.75 | 1416 | 0.79 |
| 1400 | 1160 | 0.57 | 1202 | 0.61 | 1243 | 0.65 | 1283 | 0.69 | 1322 | 0.73 | 1359 | 0.78 | 1396 | 0.82 | 1432 | 0.87 |
| 1500 | 1182 | 0.64 | 1223 | 0.68 | 1263 | 0.72 | 1303 | 0.76 | 1341 | 0.81 | 1378 | 0.85 | 1414 | 0.90 | 1449 | 0.94 |
| 1600 | 1205 | 0.70 | 1245 | 0.75 | 1284 | 0.79 | 1323 | 0.84 | 1361 | 0.88 | 1397 | 0.93 | 1432 | 0.98 | 1467 | 1.03 |
| 1700 | 1228 | 0.78 | 1268 | 0.82 | 1307 | 0.87 | 1345 | 0.92 | 1382 | 0.97 | 1417 | 1.02 | 1452 | 1.07 | 1486 | 1.11 |
| 1800 | 1253 | 0.85 | 1292 | 0.91 | 1331 | 0.96 | 1368 | 1.01 | 1404 | 1.06 | 1439 | 1.11 | 1473 | 1.16 | 1506 | 1.21 |
| 1900 | 1279 | 0.94 | 1317 | 1.00 | 1355 | 1.05 | 1392 | 1.10 | 1427 | 1.16 | 1461 | 1.21 | 1494 | 1.26 | 1527 | 1.31 |
| 2000 | 1305 | 1.04 | 1343 | 1.10 | 1380 | 1.15 | 1416 | 1.21 | 1450 | 1.26 | 1484 | 1.32 | 1516 | 1.37 | 1549 | 1.42 |

HORIZONTAL

| Air Volume cfm | External Static - in. w.g. | | | | | | | | | | | | | | | |
|-------------------|----------------------------|------|------|------|------|------|---------|------|------|------|------|------|------|------|------|------|
| | 0.10 | | 0.20 | | 0.30 | | 0.40 | | 0.50 | | 0.60 | | 0.70 | | 0.80 | |
| | RPM | BHP | RPM | BHP | RPM | BHP | RPM | BHP | RPM | BHP | RPM | BHP | RPM | BHP | RPM | BHP |
| | Field Furnished | | | | | | Kit Z02 | | | | | | | | | |
| 1200 | 687 | 0.23 | 757 | 0.26 | 826 | 0.29 | 893 | 0.32 | 955 | 0.35 | 1008 | 0.39 | 1054 | 0.42 | 1095 | 0.46 |
| 1300 | 730 | 0.27 | 798 | 0.30 | 864 | 0.33 | 926 | 0.37 | 982 | 0.40 | 1030 | 0.44 | 1073 | 0.47 | 1116 | 0.51 |
| 1400 | 775 | 0.31 | 840 | 0.34 | 902 | 0.38 | 959 | 0.42 | 1009 | 0.46 | 1054 | 0.50 | 1096 | 0.53 | 1140 | 0.56 |
| 1500 | 820 | 0.36 | 881 | 0.40 | 939 | 0.44 | 993 | 0.49 | 1039 | 0.53 | 1082 | 0.56 | 1124 | 0.59 | 1168 | 0.62 |
| 1600 | 864 | 0.42 | 921 | 0.46 | 976 | 0.51 | 1027 | 0.56 | 1072 | 0.60 | 1113 | 0.63 | 1155 | 0.66 | 1198 | 0.69 |
| 1700 | 907 | 0.48 | 961 | 0.53 | 1013 | 0.58 | 1061 | 0.63 | 1105 | 0.67 | 1146 | 0.70 | 1187 | 0.73 | 1230 | 0.77 |
| 1800 | 948 | 0.56 | 999 | 0.61 | 1049 | 0.66 | 1096 | 0.71 | 1139 | 0.75 | 1180 | 0.78 | 1221 | 0.82 | 1262 | 0.86 |
| 1900 | 987 | 0.64 | 1037 | 0.69 | 1086 | 0.74 | 1132 | 0.79 | 1174 | 0.83 | 1214 | 0.86 | 1255 | 0.90 | 1295 | 0.95 |
| 2000 | 1028 | 0.73 | 1076 | 0.78 | 1123 | 0.83 | 1168 | 0.87 | 1210 | 0.91 | 1250 | 0.96 | 1289 | 1.00 | 1328 | 1.06 |

| Air Volume cfm | External Static - in. w.g. | | | | | | | | | | | | | | | |
|-------------------|----------------------------|------|------|------|------|------|---------|------|------|------|------|------|------|------|------|------|
| | 0.90 | | 1.00 | | 1.10 | | 1.20 | | 1.30 | | 1.40 | | 1.50 | | 1.60 | |
| | RPM | BHP | RPM | BHP | RPM | BHP | RPM | BHP | RPM | BHP | RPM | BHP | RPM | BHP | RPM | BHP |
| | Kit Z02 | | | | | | Kit Z05 | | | | | | | | | |
| 1200 | 1139 | 0.49 | 1187 | 0.52 | 1234 | 0.54 | 1276 | 0.58 | 1314 | 0.62 | 1350 | 0.66 | 1385 | 0.71 | 1421 | 0.75 |
| 1300 | 1161 | 0.54 | 1208 | 0.57 | 1254 | 0.60 | 1295 | 0.64 | 1332 | 0.69 | 1366 | 0.73 | 1401 | 0.78 | 1436 | 0.83 |
| 1400 | 1185 | 0.59 | 1232 | 0.63 | 1276 | 0.67 | 1315 | 0.71 | 1351 | 0.76 | 1384 | 0.81 | 1419 | 0.86 | 1454 | 0.90 |
| 1500 | 1212 | 0.66 | 1257 | 0.70 | 1299 | 0.74 | 1337 | 0.79 | 1371 | 0.84 | 1404 | 0.89 | 1438 | 0.94 | 1473 | 0.99 |
| 1600 | 1242 | 0.73 | 1284 | 0.77 | 1324 | 0.82 | 1360 | 0.88 | 1394 | 0.93 | 1426 | 0.99 | 1460 | 1.04 | 1495 | 1.08 |
| 1700 | 1272 | 0.81 | 1312 | 0.86 | 1350 | 0.92 | 1385 | 0.98 | 1418 | 1.04 | 1451 | 1.09 | 1485 | 1.14 | 1519 | 1.19 |
| 1800 | 1302 | 0.90 | 1341 | 0.96 | 1377 | 1.02 | 1411 | 1.08 | 1444 | 1.15 | 1477 | 1.20 | 1510 | 1.25 | 1544 | 1.30 |
| 1900 | 1334 | 1.01 | 1371 | 1.07 | 1406 | 1.13 | 1439 | 1.20 | 1471 | 1.26 | 1504 | 1.32 | 1537 | 1.37 | 1571 | 1.41 |
| 2000 | 1365 | 1.12 | 1401 | 1.19 | 1435 | 1.25 | 1468 | 1.32 | 1500 | 1.38 | 1532 | 1.44 | 1565 | 1.49 | 1598 | 1.53 |

BLOWER DATA - BELT DRIVE - ZHA060

BLOWER TABLE INCLUDES RESISTANCE FOR BASE UNIT ONLY WITH DRY INDOOR COIL AND AIR FILTERS IN PLACE.

FOR ALL UNITS ADD:

1 - Any factory installed options air resistance (heat section, economizer, wet coil, etc.).

2 - Any field installed accessories air resistance (duct resistance, diffuser, etc.).

See page 12 for blower motors and drives and wet coil and options/accessory air resistance data.

DOWNFLOW

| Air Volume cfm | External Static - in. w.g. | | | | | | | | | | | | | | | |
|-------------------|----------------------------|------|------|------|------|------|---------|------|------|------|------|------|------|------|------|------|
| | 0.10 | | 0.20 | | 0.30 | | 0.40 | | 0.50 | | 0.60 | | 0.70 | | 0.80 | |
| | RPM | BHP | RPM | BHP | RPM | BHP | RPM | BHP | RPM | BHP | RPM | BHP | RPM | BHP | RPM | BHP |
| | Field Furnished | | | | | | Kit Z03 | | | | | | | | | |
| 1600 | 764 | 0.35 | 822 | 0.39 | 880 | 0.42 | 936 | 0.46 | 991 | 0.51 | 1042 | 0.55 | 1091 | 0.60 | 1136 | 0.64 |
| 1700 | 801 | 0.40 | 857 | 0.44 | 913 | 0.48 | 968 | 0.52 | 1020 | 0.57 | 1070 | 0.61 | 1117 | 0.66 | 1162 | 0.71 |
| 1800 | 838 | 0.46 | 893 | 0.50 | 947 | 0.54 | 1000 | 0.58 | 1051 | 0.63 | 1099 | 0.68 | 1145 | 0.73 | 1188 | 0.78 |
| 1900 | 876 | 0.52 | 929 | 0.56 | 982 | 0.61 | 1033 | 0.65 | 1082 | 0.70 | 1129 | 0.75 | 1173 | 0.80 | 1215 | 0.85 |
| 2000 | 914 | 0.59 | 966 | 0.63 | 1017 | 0.68 | 1067 | 0.72 | 1115 | 0.77 | 1160 | 0.83 | 1203 | 0.88 | 1244 | 0.94 |
| 2100 | 953 | 0.66 | 1004 | 0.71 | 1054 | 0.76 | 1102 | 0.81 | 1148 | 0.86 | 1192 | 0.92 | 1233 | 0.98 | 1273 | 1.04 |
| 2200 | 993 | 0.74 | 1042 | 0.79 | 1090 | 0.85 | 1137 | 0.90 | 1181 | 0.96 | 1224 | 1.02 | 1264 | 1.09 | 1303 | 1.15 |
| 2300 | 1033 | 0.83 | 1081 | 0.89 | 1128 | 0.94 | 1173 | 1.01 | 1216 | 1.07 | 1257 | 1.14 | 1296 | 1.20 | 1334 | 1.27 |
| 2400 | 1074 | 0.93 | 1120 | 0.99 | 1166 | 1.05 | 1209 | 1.12 | 1251 | 1.19 | 1291 | 1.26 | 1329 | 1.33 | 1366 | 1.41 |

| Air Volume cfm | External Static - in. w.g. | | | | | | | | | | | | | | | |
|-------------------|----------------------------|------|------|------|------|------|------|------|------|------|---------|------|------|------|------|------|
| | 0.90 | | 1.00 | | 1.10 | | 1.20 | | 1.30 | | 1.40 | | 1.50 | | 1.60 | |
| | RPM | BHP | RPM | BHP | RPM | BHP | RPM | BHP | RPM | BHP | RPM | BHP | RPM | BHP | RPM | BHP |
| | Kit Z03 | | | | | | | | | | Kit Z06 | | | | | |
| 1600 | 1180 | 0.68 | 1222 | 0.72 | 1263 | 0.76 | 1303 | 0.80 | 1341 | 0.85 | 1378 | 0.90 | 1414 | 0.94 | 1449 | 0.99 |
| 1700 | 1204 | 0.75 | 1245 | 0.79 | 1285 | 0.84 | 1325 | 0.88 | 1362 | 0.93 | 1398 | 0.98 | 1434 | 1.03 | 1468 | 1.08 |
| 1800 | 1229 | 0.83 | 1270 | 0.87 | 1309 | 0.92 | 1347 | 0.97 | 1384 | 1.02 | 1420 | 1.07 | 1454 | 1.12 | 1488 | 1.17 |
| 1900 | 1256 | 0.91 | 1296 | 0.96 | 1334 | 1.01 | 1371 | 1.07 | 1407 | 1.12 | 1442 | 1.17 | 1476 | 1.23 | 1509 | 1.28 |
| 2000 | 1284 | 1.00 | 1322 | 1.06 | 1360 | 1.11 | 1396 | 1.17 | 1431 | 1.23 | 1465 | 1.28 | 1498 | 1.33 | 1531 | 1.38 |
| 2100 | 1312 | 1.10 | 1350 | 1.16 | 1386 | 1.22 | 1422 | 1.28 | 1456 | 1.34 | 1489 | 1.40 | 1521 | 1.45 | 1554 | 1.50 |
| 2200 | 1341 | 1.22 | 1378 | 1.28 | 1414 | 1.34 | 1448 | 1.41 | 1481 | 1.46 | 1513 | 1.52 | 1546 | 1.57 | 1578 | 1.62 |
| 2300 | 1371 | 1.34 | 1407 | 1.41 | 1442 | 1.47 | 1475 | 1.54 | 1507 | 1.59 | 1539 | 1.65 | 1571 | 1.70 | 1602 | 1.75 |
| 2400 | 1402 | 1.48 | 1436 | 1.55 | 1470 | 1.61 | 1503 | 1.67 | 1535 | 1.73 | 1566 | 1.79 | 1597 | 1.84 | 1628 | 1.89 |

HORIZONTAL

| Air Volume cfm | External Static - in. w.g. | | | | | | | | | | | | | | | |
|-------------------|----------------------------|------|------|------|------|------|---------|------|------|------|------|------|------|------|------|------|
| | 0.10 | | 0.20 | | 0.30 | | 0.40 | | 0.50 | | 0.60 | | 0.70 | | 0.80 | |
| | RPM | BHP | RPM | BHP | RPM | BHP | RPM | BHP | RPM | BHP | RPM | BHP | RPM | BHP | RPM | BHP |
| | Field Furnished | | | | | | Kit Z03 | | | | | | | | | |
| 1600 | 783 | 0.38 | 844 | 0.41 | 902 | 0.44 | 957 | 0.48 | 1008 | 0.52 | 1056 | 0.56 | 1100 | 0.60 | 1142 | 0.64 |
| 1700 | 825 | 0.44 | 882 | 0.47 | 938 | 0.50 | 989 | 0.54 | 1038 | 0.57 | 1083 | 0.62 | 1126 | 0.66 | 1166 | 0.71 |
| 1800 | 866 | 0.50 | 921 | 0.53 | 973 | 0.56 | 1021 | 0.60 | 1067 | 0.64 | 1111 | 0.68 | 1152 | 0.73 | 1191 | 0.78 |
| 1900 | 907 | 0.56 | 959 | 0.59 | 1008 | 0.63 | 1054 | 0.66 | 1098 | 0.71 | 1139 | 0.75 | 1179 | 0.80 | 1217 | 0.86 |
| 2000 | 948 | 0.63 | 996 | 0.66 | 1042 | 0.70 | 1086 | 0.74 | 1128 | 0.78 | 1168 | 0.83 | 1207 | 0.89 | 1244 | 0.94 |
| 2100 | 987 | 0.70 | 1033 | 0.74 | 1077 | 0.78 | 1119 | 0.82 | 1159 | 0.87 | 1198 | 0.93 | 1235 | 0.99 | 1272 | 1.05 |
| 2200 | 1026 | 0.78 | 1070 | 0.82 | 1112 | 0.87 | 1152 | 0.92 | 1191 | 0.98 | 1228 | 1.03 | 1265 | 1.10 | 1301 | 1.16 |
| 2300 | 1064 | 0.88 | 1106 | 0.92 | 1147 | 0.97 | 1186 | 1.03 | 1223 | 1.09 | 1260 | 1.15 | 1295 | 1.22 | 1331 | 1.28 |
| 2400 | 1102 | 0.98 | 1143 | 1.03 | 1182 | 1.08 | 1220 | 1.15 | 1256 | 1.21 | 1292 | 1.28 | 1327 | 1.35 | 1362 | 1.42 |

| Air Volume cfm | External Static - in. w.g. | | | | | | | | | | | | | | | |
|-------------------|----------------------------|------|------|------|------|------|------|------|------|------|---------|------|------|------|------|------|
| | 0.90 | | 1.00 | | 1.10 | | 1.20 | | 1.30 | | 1.40 | | 1.50 | | 1.60 | |
| | RPM | BHP | RPM | BHP | RPM | BHP | RPM | BHP | RPM | BHP | RPM | BHP | RPM | BHP | RPM | BHP |
| | Kit Z03 | | | | | | | | | | Kit Z06 | | | | | |
| 1600 | 1183 | 0.68 | 1223 | 0.72 | 1263 | 0.76 | 1302 | 0.81 | 1340 | 0.86 | 1377 | 0.91 | 1413 | 0.95 | 1448 | 1.00 |
| 1700 | 1205 | 0.75 | 1245 | 0.79 | 1284 | 0.84 | 1322 | 0.89 | 1360 | 0.94 | 1396 | 0.99 | 1431 | 1.04 | 1465 | 1.09 |
| 1800 | 1230 | 0.83 | 1268 | 0.87 | 1306 | 0.92 | 1344 | 0.98 | 1380 | 1.03 | 1416 | 1.08 | 1450 | 1.13 | 1483 | 1.19 |
| 1900 | 1255 | 0.91 | 1292 | 0.96 | 1330 | 1.02 | 1367 | 1.07 | 1402 | 1.13 | 1437 | 1.18 | 1470 | 1.24 | 1503 | 1.29 |
| 2000 | 1281 | 1.00 | 1318 | 1.06 | 1355 | 1.12 | 1391 | 1.18 | 1425 | 1.23 | 1459 | 1.29 | 1492 | 1.35 | 1524 | 1.40 |
| 2100 | 1308 | 1.11 | 1345 | 1.17 | 1381 | 1.23 | 1416 | 1.29 | 1450 | 1.35 | 1482 | 1.41 | 1514 | 1.46 | 1546 | 1.52 |
| 2200 | 1337 | 1.23 | 1372 | 1.29 | 1408 | 1.35 | 1442 | 1.42 | 1475 | 1.47 | 1507 | 1.53 | 1538 | 1.59 | 1569 | 1.64 |
| 2300 | 1366 | 1.35 | 1401 | 1.42 | 1435 | 1.49 | 1469 | 1.55 | 1501 | 1.61 | 1532 | 1.67 | 1563 | 1.72 | 1594 | 1.77 |
| 2400 | 1396 | 1.49 | 1431 | 1.56 | 1464 | 1.63 | 1496 | 1.69 | 1528 | 1.75 | 1559 | 1.81 | 1589 | 1.86 | 1619 | 1.91 |

BLOWER DATA

DRIVE KIT SPECIFICATIONS

| Model No. | Blower Motor Choice (HP) | | | | Drive Kit No. | RPM Range |
|-----------|--------------------------|---------|---------|---------|------------------|-------------|
| | Nominal | Maximum | Nominal | Maximum | | |
| 036 | 1 | 1.15 | 1.5 | 1.7 | Z01 | 678 - 1035 |
| | | | | | Z04 | 964 - 1471 |
| 048 | 1 | 1.15 | 1.5 | 1.7 | Z02 | 803 - 1226 |
| | | | | | ¹ Z05 | 1098 - 1490 |
| 060 | 1 | 1.15 | 1.5 | 1.7 | Z03 | 906 - 1383 |
| | | | | | ¹ Z06 | 1262 - 1634 |

NOTE - Using total air volume and system static pressure requirements determine from blower performance tables rpm and motor hp required. Maximum usable hp of motors furnished are shown. In Canada, nominal motor hp is also maximum usable motor hp. If motors of comparable hp are used, be sure to keep within the service factor limitations outlined on the motor nameplate.

¹ 1.5 hp motor is required with Z05 and Z06 drive kits.

POWER EXHAUST FAN PERFORMANCE

| Return Air System Static Pressure - in. w.g. | Air Volume Exhausted cfm |
|--|-----------------------------|
| 0.00 | 1865 |
| 0.05 | 1785 |
| 0.10 | 1710 |
| 0.15 | 1630 |
| 0.20 | 1545 |
| 0.25 | 1450 |
| 0.30 | 1350 |
| 0.35 | 1240 |

OPTIONS / ACCESSORIES AIR RESISTANCE - in. w.g.

| Air Volume cfm | Wet Indoor Coil | | Electric Heat | Economizer | |
|-------------------|-----------------|------|---------------|------------|------------|
| | 036-048 | 060 | | Downflow | Horizontal |
| 900 | 0.01 | --- | 0.02 | 0.04 | 0.05 |
| 1000 | 0.02 | --- | 0.04 | 0.04 | 0.05 |
| 1100 | 0.02 | --- | 0.05 | 0.04 | 0.06 |
| 1200 | 0.02 | --- | 0.06 | 0.05 | 0.06 |
| 1300 | 0.03 | --- | 0.08 | 0.05 | 0.07 |
| 1400 | 0.03 | --- | 0.09 | 0.06 | 0.07 |
| 1500 | 0.04 | --- | 0.10 | 0.07 | 0.08 |
| 1600 | 0.04 | 0.03 | 0.12 | 0.08 | 0.09 |
| 1700 | 0.05 | 0.04 | 0.13 | 0.08 | 0.10 |
| 1800 | 0.05 | 0.04 | 0.15 | 0.09 | 0.11 |
| 1900 | 0.06 | 0.05 | 0.16 | 0.10 | 0.12 |
| 2000 | 0.06 | 0.05 | 0.17 | 0.12 | 0.13 |
| 2100 | --- | 0.06 | 0.19 | 0.13 | 0.14 |
| 2200 | --- | 0.06 | 0.20 | 0.14 | 0.15 |
| 2300 | --- | 0.07 | 0.21 | 0.15 | 0.17 |
| 2400 | --- | 0.07 | 0.23 | 0.17 | 0.18 |

CEILING DIFFUSERS AIR RESISTANCE (in. w.g.)

| Air Volume cfm | RTD9-65 Step-Down Diffuser | | | FD9-65 Flush Diffuser |
|-------------------|----------------------------|-------------------------|--------------------------|-----------------------------|
| | 2 Ends Open | 1 Side & 2 Ends Open | All Ends & Sides Open | |
| 800 | 0.15 | 0.13 | 0.11 | 0.11 |
| 1000 | 0.19 | 0.16 | 0.14 | 0.14 |
| 1200 | 0.25 | 0.20 | 0.17 | 0.17 |
| 1400 | 0.33 | 0.26 | 0.20 | 0.20 |
| 1600 | 0.43 | 0.32 | 0.20 | 0.24 |
| 1800 | 0.56 | 0.40 | 0.30 | 0.30 |
| 2000 | 0.73 | 0.50 | 0.36 | 0.36 |
| 2200 | 0.95 | 0.63 | 0.44 | 0.44 |

CEILING DIFFUSER AIR THROW DATA

| Air Volume - cfm | ¹ Effective Throw - ft. | |
|------------------|------------------------------------|---------|
| Model No. | RTD9-65 | FD9-65 |
| 800 | 10 - 17 | 14 - 18 |
| 1000 | 10 - 17 | 15 - 20 |
| 1200 | 11 - 18 | 16 - 22 |
| 1400 | 12 - 19 | 17 - 24 |
| 1600 | 12 - 20 | 18 - 25 |
| 1800 | 13 - 21 | 20 - 28 |
| 2000 | 14 - 23 | 21 - 29 |
| 2200 | 16 - 25 | 22 - 30 |

¹ Effective throw based on terminal velocities of 75 ft. per minute.

**TABLE 2
DRIVE COMPONENT MANUFACTURER'S NUMBERS**

| Drive No. | DRIVE COMPONENT PART NUMBERS | | | | | |
|-----------|------------------------------|----------|---------------|-----------|----------|-----------|
| | Motor Pulley | | Blower Pulley | | Belts | |
| | Browning | OEM | Browning | OEM | Browning | OEM |
| Z01 | 1VP34 X 7/8 | 31K6901 | AK54 X 5/8 | 100244-30 | A40 | 100245-17 |
| Z02 | 1VP34 X 7/8 | 31K6901 | AK46 X 5/8 | 100244-31 | A39 | 100245-16 |
| Z03 | 1VP34 X 7/8 | 31K6901 | AK41 X 5/8 | 100244-28 | A39 | 100245-16 |
| Z04 | 1VP34 X 7/8 | 31K6901 | AK39 X 5/8 | 100244-32 | A38 | 100245-15 |
| Z05 | 1VP44 X 7/8 | P-8-1488 | AK49 X 5/8 | 100244-26 | A41 | 100245-18 |
| Z06 | 1VP50 X 7/8 | 53J1501 | AK51 X 5/8 | 100244-29 | A42 | 100245-19 |

**TABLE 3
MINIMUM AIRFLOW - UNITS WITH ELECTRIC HEAT**

| Kw | CFM |
|------|-------------------------|
| | Downflow and Horizontal |
| 5 | 1080 |
| 7.5 | 1080 |
| 10 | 1080 |
| 15 | 1080 |
| 22.5 | 1440 |

Units with electric heat (5-22.5kW) can operate up to 1.6" w.g. maximum static pressure.

Start-Up

▲ IMPORTANT

If unit is equipped with a crankcase heater. Make sure heater is energized 24 hours before unit start-up to prevent compressor damage as a result of slugging.

A-Start-Up

Heating

- 1- Set thermostat or temperature control device to initiate a first-stage heating demand.
- 2- A first-stage heating demand (W1) will energize compressors 1 and the outdoor fan.

Note - L1 reversing valve is de-energized in the heating mode.

ZHA Units With Optional Electric Heat -

An increased heating demand (W2) will energize electric heat. Electric heat is also energized during the defrost cycle (W1) to maintain discharge air temperature.

Cooling

- 1- Set thermostat or temperature control device fan switch to **AUTO** or **ON**. Set thermostat or temperature control device to initiate a first-stage cooling demand.

A first-stage Y1 cooling demand will energize L1 reversing valve solenoid and compressor 1.

Units With Optional Economizer -

The optional economizer will start on a first stage (Y1) cooling demand when outdoor air is suitable. An increased cooling demand (Y2) will energize compressor 1.

- 2- Refrigerant circuits are factory charged with R-410A refrigerant. See unit rating plate for correct amount of charge.

B-Three Phase Scroll Compressor Voltage Phasing

Three phase scroll compressors must be phased sequentially to ensure correct compressor and blower rotation and operation. Compressor and blower are wired in phase at the factory. Power wires are color-coded as follows: line 1-red, line 2-yellow, line 3-blue.

- 1- Observe suction and discharge pressures and blower rotation on unit start-up.
- 2- Suction pressure must drop, discharge pressure must rise, and blower rotation must match rotation marking.

If pressure differential is not observed or blower rotation is not correct:

- 3- Disconnect all remote electrical power supplies.
- 4- Reverse any two field-installed wires connected to the line side of K1 contactor. Do not reverse wires at blower contactor.

Make sure the connections are tight.

Discharge and suction pressures should operate at their normal start-up ranges.

C - Refrigerant Charge and Check

WARNING-Do not exceed nameplate charge under any condition.

This unit is factory charged and should require no further adjustment. If the system requires additional refrigerant, reclaim the charge, evacuate the system, and add required nameplate charge.

*NOTE - System charging is not recommended below 60°F (15°C). In temperatures below 60°F (15°C), the charge **must** be weighed into the system.*

If weighing facilities are not available, or to check the charge, use the following procedure:

IMPORTANT - Charge unit in standard cooling mode high stage only.

- 1- Make sure outdoor coil is clean. Attach gauge manifolds and operate unit at full CFM in cooling mode with economizer disabled until system stabilizes (approximately five minutes). Make sure all outdoor air dampers are closed.
- 2- Compare the normal operating pressures (see tables 4 - 6) to the pressures obtained from the gauges. Check unit components if there are significant differences.
- 3- Measure the outdoor ambient temperature and the suction pressure. Refer to the appropriate circuit charging curve to determine a target liquid temperature.

Note - Pressures are listed for sea level applications.

- 4- Use the same thermometer to accurately measure the liquid temperature (in the outdoor section).
 - If measured liquid temperature is higher than the target liquid temperature, add refrigerant to the system.
 - If measured liquid temperature is lower than the target liquid temperature, recover some refrigerant from the system.
- 5- Add or remove charge in increments. Allow the system to stabilize each time refrigerant is added or removed.

6- Continue the process until measured liquid temperature agrees with the target liquid temperature. Do not go below the target liquid temperature when adjusting charge. Note that suction pressure can change as charge is adjusted.

7- Example ZH 036: At 95°F outdoor ambient and a measured suction pressure of 130psig, the target liquid temperature is 105.5°F. For a measured liquid temperature of 106°F, add charge in increments until measured liquid temperature agrees with the target liquid temperature.

D - Compressor Controls

See unit wiring diagram to determine which controls are used in each unit. Optional controls are identified on wiring diagrams by arrows at junction points.

- 1- Defrost Switch (S6)
Defrost switch closes to initiate defrost when liquid line temperature falls to 42°F (5.6°C). Defrost switch opens when liquid line temperature reaches 70°F (21°C) to terminate defrost. If the liquid line temperature does not rise above 70°F (21°C), the CMC1 will terminate defrost after 14 minutes. The defrost switch is located on the liquid line between the outdoor expansion valve and the distributor
- 2- Defrost Control (CMC1)
Defrost is liquid line temperature initiated and operates for 14 minutes unless terminated by liquid line temperature.

When the liquid line temperature drops below 42°F (5.6°C), the defrost switch closes and signals the **defrost control** that a defrost cycle is needed. If the defrost switch is still closed after 90 minutes (default), a defrost cycle begins and operates for up to 14 minutes. The defrost switch can terminate the defrost cycle before the 14 minutes elapses if liquid line temperature reaches 70°F (21°C)

Electric heat is energized during defrost to maintain discharge air temperature.

**TABLE 4
ZH 036 NORMAL OPERATING PRESSURES**

| Outdoor Coil Entering Air Temperature | | | | | | | | | | | |
|---------------------------------------|-------------|-------------|-------------|-------------|-------------|-------------|-------------|-------------|-------------|-------------|-------------|
| 65 °F | | 75 °F | | 85 °F | | 95 °F | | 105 °F | | 115 °F | |
| Suct (psig) | Disc (psig) | Suct (psig) | Disc (psig) | Suct (psig) | Disc (psig) | Suct (psig) | Disc (psig) | Suct (psig) | Disc (psig) | Suct (psig) | Disc (psig) |
| 119 | 235 | 122 | 272 | 124 | 314 | 126 | 359 | 129 | 409 | 132 | 461 |
| 128 | 241 | 130 | 279 | 132 | 319 | 136 | 364 | 146 | 421 | 140 | 470 |
| 139 | 245 | 146 | 285 | 151 | 331 | 155 | 377 | 155 | 428 | 159 | 482 |
| 145 | 248 | 154 | 290 | 163 | 335 | 170 | 384 | 174 | 438 | 179 | 498 |

**TABLE 5
ZH 048 NORMAL OPERATING PRESSURES**

| Outdoor Coil Entering Air Temperature | | | | | | | | | | | |
|---------------------------------------|-------------|-------------|-------------|-------------|-------------|-------------|-------------|-------------|-------------|-------------|-------------|
| 65 °F | | 75 °F | | 85 °F | | 95 °F | | 105 °F | | 115 °F | |
| Suct (psig) | Disc (psig) | Suct (psig) | Disc (psig) | Suct (psig) | Disc (psig) | Suct (psig) | Disc (psig) | Suct (psig) | Disc (psig) | Suct (psig) | Disc (psig) |
| 113 | 253 | 116 | 293 | 119 | 336 | 122 | 383 | 125 | 435 | 128 | 492 |
| 121 | 258 | 123 | 297 | 126 | 341 | 129 | 387 | 133 | 440 | 137 | 498 |
| 133 | 267 | 138 | 308 | 143 | 354 | 146 | 401 | 151 | 459 | 154 | 516 |
| 140 | 273 | 148 | 317 | 155 | 366 | 161 | 418 | 167 | 475 | 172 | 536 |

**TABLE 6
ZH 060 NORMAL OPERATING PRESSURES**

| Outdoor Coil Entering Air Temperature | | | | | | | | | | | |
|---------------------------------------|-------------|-------------|-------------|-------------|-------------|-------------|-------------|-------------|-------------|-------------|-------------|
| 65 °F | | 75 °F | | 85 °F | | 95 °F | | 105 °F | | 115 °F | |
| Suct (psig) | Disc (psig) | Suct (psig) | Disc (psig) | Suct (psig) | Disc (psig) | Suct (psig) | Disc (psig) | Suct (psig) | Disc (psig) | Suct (psig) | Disc (psig) |
| 113 | 254 | 115 | 292 | 119 | 335 | 122 | 380 | 125 | 430 | 128 | 487 |
| 121 | 260 | 123 | 299 | 126 | 343 | 130 | 391 | 134 | 440 | 137 | 496 |
| 130 | 265 | 138 | 308 | 143 | 354 | 147 | 404 | 151 | 456 | 154 | 513 |
| 136 | 270 | 145 | 315 | 153 | 364 | 160 | 414 | 167 | 471 | 172 | 529 |

ZH 036 CHARGING CURVE

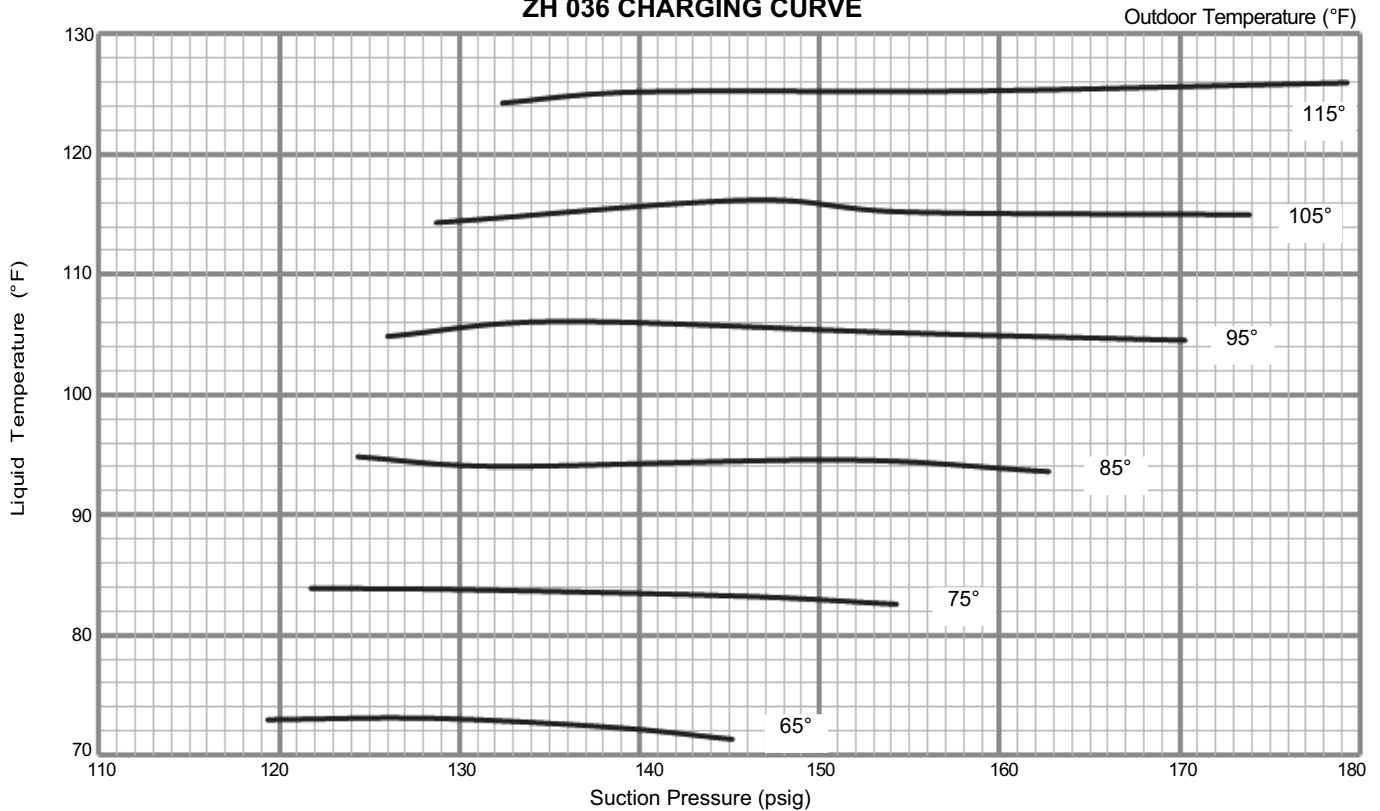

ZH 048 CHARGING CURVE

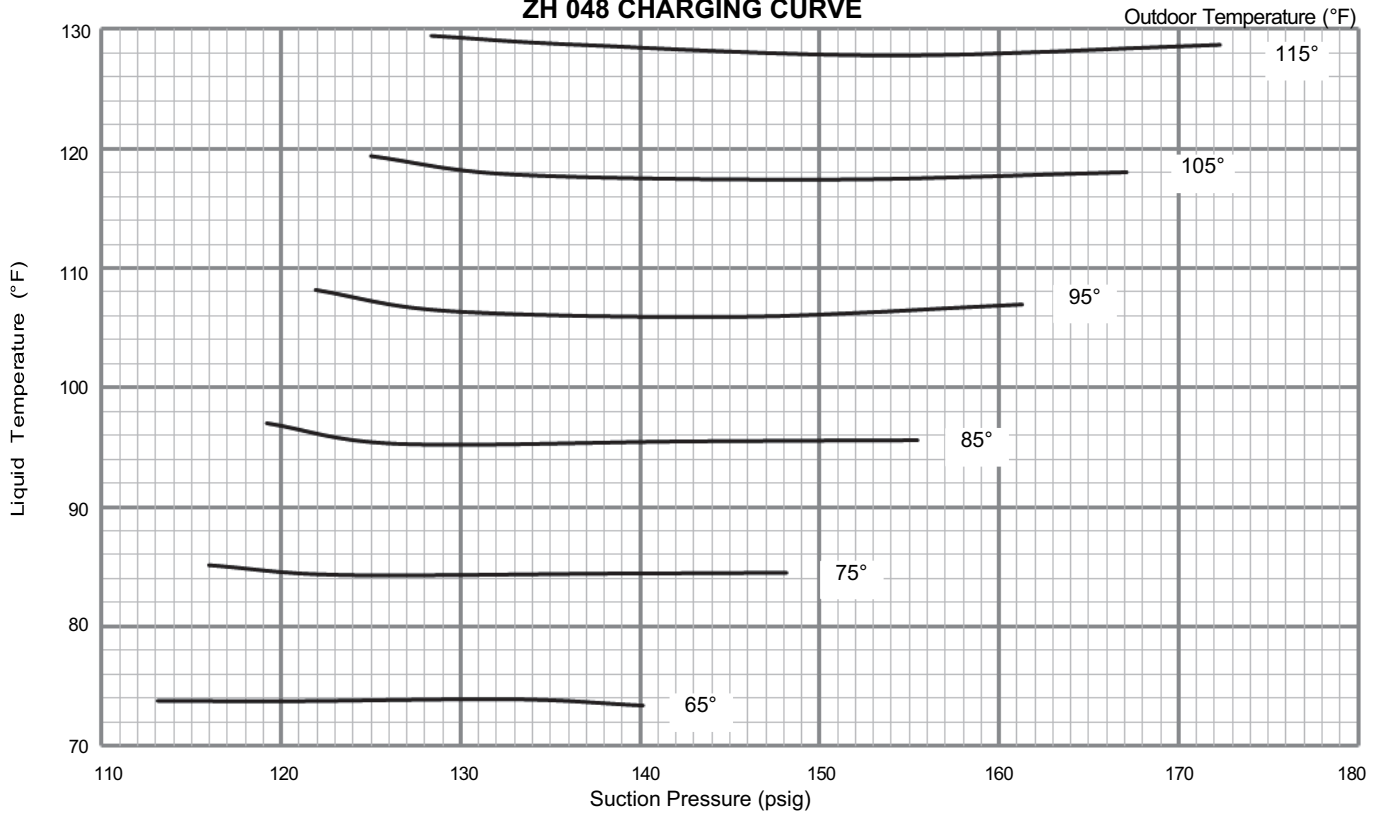

ZH 060 CHARGING CURVE

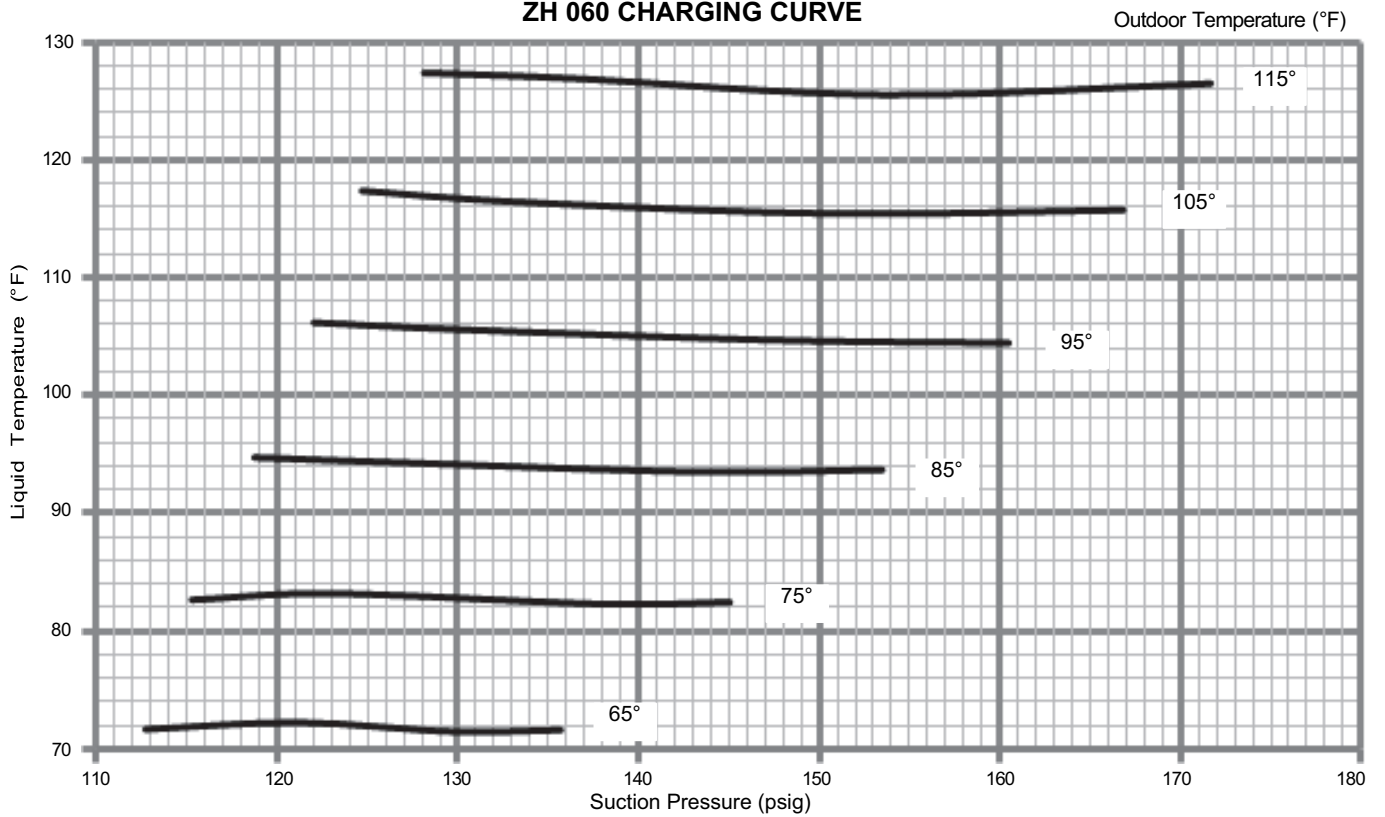

Defrost Control Board

The defrost thermostat and the defrost control work together to ensure that the heat pump outdoor coil does not ice excessively during the heating mode.

Compressor Accumulated Run-Time Interval

The defrost control will not energize a defrost cycle unless the unit has been operating in heating mode for an accumulated 90 minutes (default). The run time interval can be changed by moving the jumper on the CMC board timing pins. See figure 12.

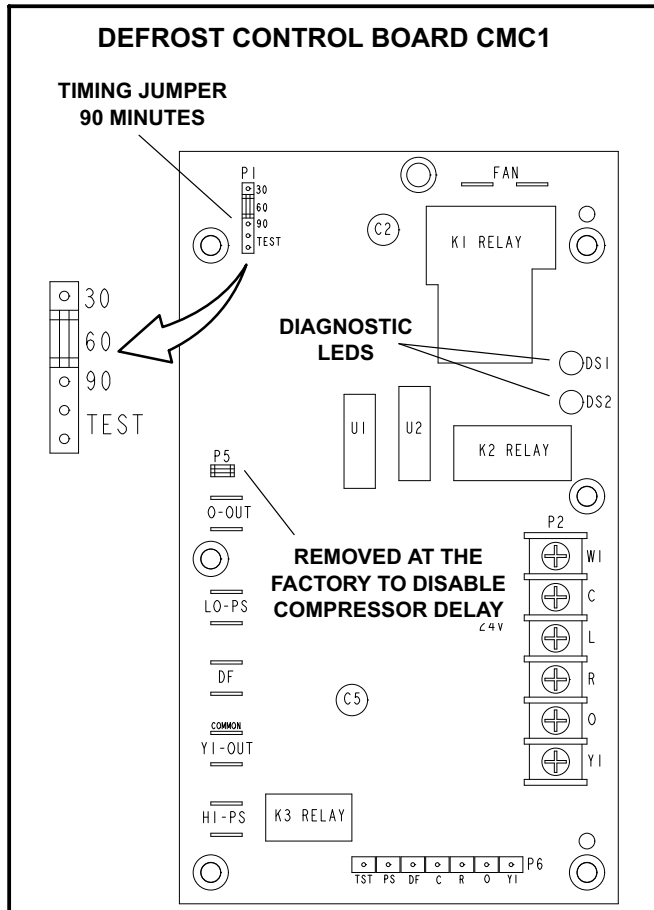

FIGURE 12

The defrost interval can be adjusted to 30, 60, or 90 minutes. The defrost timing jumper is factory-installed to provide a 90-minute defrost interval. If the timing selector jumper is not in place, the control defaults to a 90-minute defrost interval.

Defrost Test Option

A TEST option is provided for troubleshooting. The TEST mode may be started any time the unit is in the heating mode and the defrost thermostat is closed or jumpered. If the timing jumper is in the TEST position at power-up, the defrost control will ignore the test pins. When the jumper is placed across the TEST pins for two seconds, the control will enter the defrost mode. If the jumper is removed before an additional 5-second period has elapsed (7 seconds total), the unit will remain in defrost mode until the defrost switch opens or 14 minutes have passed. If the jumper is not removed until after the additional 5-second period has elapsed, the defrost will terminate and the test option will not function again until the jumper is removed and re-applied.

Diagnostic LEDs

The defrost board uses two LEDs for diagnostics. The LEDs flash a sequence according to the condition.

TABLE 7

| Defrost Control Board Diagnostic LED | | |
|--------------------------------------|-------------------------|---------------|
| Mode | Green LED (DS2) | Red LED (DS1) |
| No power to control | OFF | OFF |
| Normal operation / power to control | Simultaneous Slow FLASH | |
| Anti-short cycle lockout | Alternating Slow FLASH | |
| High pressure switch fault | Slow FLASH | OFF |
| High pressure switch lockout | ON | OFF |

Service

The unit should be inspected once a year by a qualified service technician.

⚠ CAUTION

Label all wires prior to disconnection when servicing controls. Wiring errors can cause improper and dangerous operation. Verify proper operation after servicing.

⚠ WARNING

The State of California has determined that this product may contain or produce a chemical or chemicals, in very low doses, which may cause serious illness or death. It may also cause cancer, birth defects, or reproductive harm.

A - Lubrication

All motors are lubricated at the factory. No further lubrication is required.

B-Compressor

If Interlink compressor replacement is necessary, call 1-800-4-LENNOX (1-800-453-6669).

⚠ IMPORTANT

Some scroll compressors have an internal vacuum protector that will unload scrolls when suction pressure goes below 20 psig. A hissing sound will be heard when the compressor is running unloaded. Protector will reset when low pressure in system rises above 40 psig. **DO NOT REPLACE COMPRESSOR.**

C - Filters

Units are equipped with temporary filters which must be replaced prior to building occupation. See table 8 for correct filter size. Refer to local codes or appropriate jurisdiction for approved filters.

To change filters, open filter access panel on back side of unit. See figure 13. Lift filter stop to remove filters. See figure 14.

⚠ WARNING

Units are shipped from the factory with temporary filters. Replace filters before building is occupied. Damage to unit could result if filters are not replaced with approved filters. Refer to appropriate codes.

Approved filters should be checked monthly and replaced when necessary. Take note of air flow direction marking on filter frame when reinstalling filters. See figure 14.

**TABLE 8
UNIT FILTERS**

| Unit | Qty | Filter Size - inches (mm) |
|----------|-----|------------------------------|
| 036, 048 | 4 | 14 X 20 X 2 (352 X 508 X 51) |
| 060 | 4 | 16 X 20 X 2 (406 X 508 X 51) |

NOTE-Filters must be U.L.C. certified or equivalent for use in Canada.

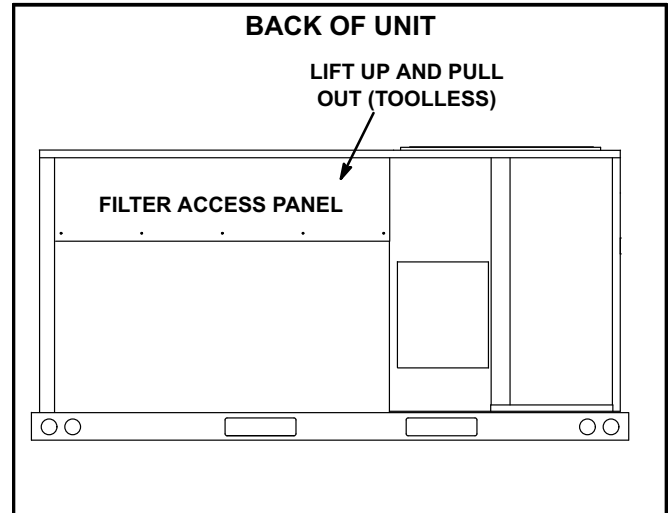

FIGURE 13

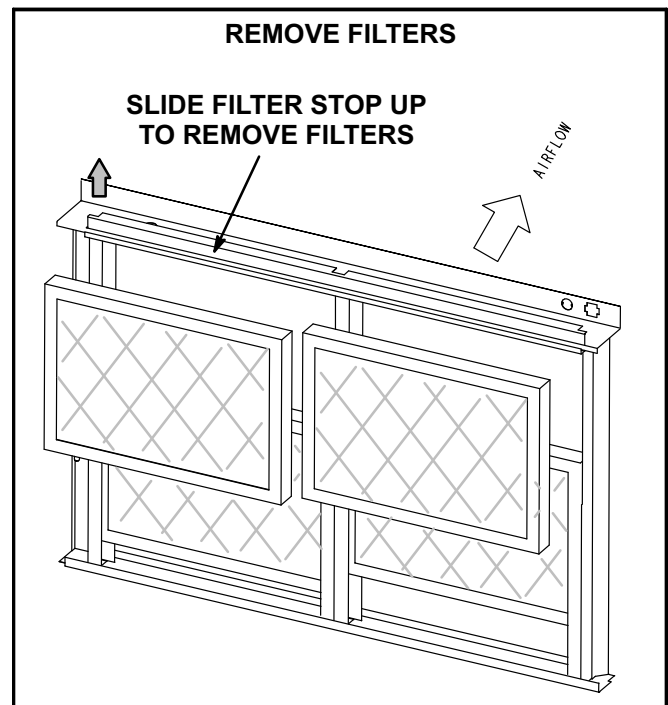

FIGURE 14

D - Supply Air Blower Wheel

Annually inspect supply air blower wheel for accumulated dirt or dust. Turn off power before attempting to remove access panel or to clean blower wheel.

E - Indoor Coil

Inspect and clean coil at beginning of each cooling and heating season. Clean using mild detergent or commercial coil cleanser. Flush coil and condensate drain with water taking care not to get insulation, filters and return air ducts wet.

F - Outdoor Coil

Clean outdoor coil annually with detergent or commercial coil cleaner and inspect monthly during the cooling season.

Outdoor coils are made of single and two formed slabs. On units with two slabs, dirt and debris may become trapped between the slabs. To clean between slabs, carefully separate coil slabs and wash them thoroughly. See figure 15. Flush coils with water following cleaning.

Note - Remove all screws and gaskets prior to cleaning procedure and replace upon completion.

G - Filter Drier

The unit is equipped with a biflow filter drier. if replacement is necessary, order another of like design.

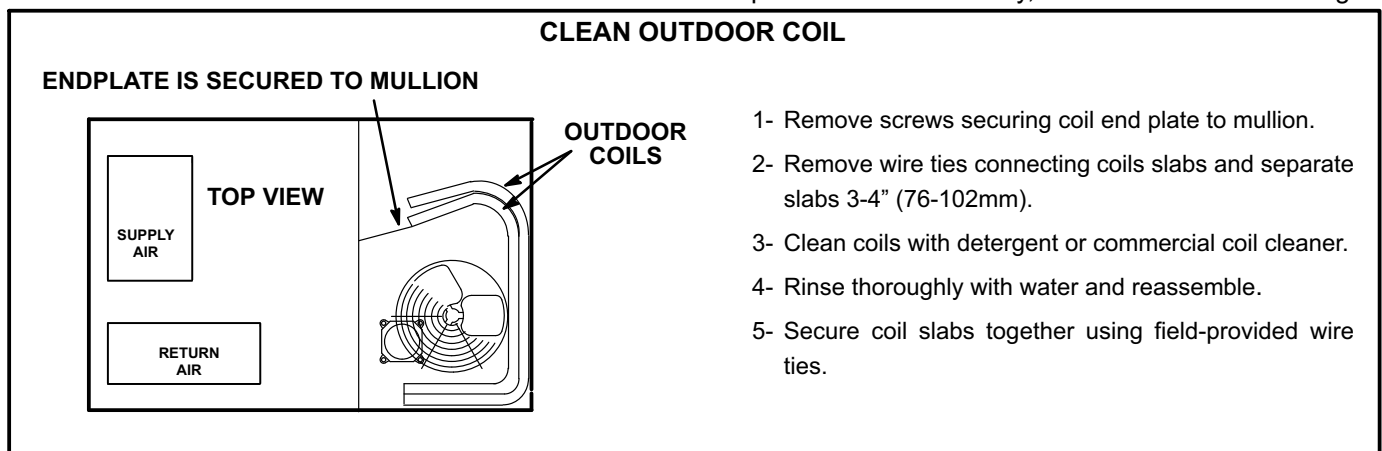

FIGURE 15